



60

# BAGNOMARIA ELETTRICI - TOP

MOD. \_\_\_\_\_  
COD. \_\_\_\_\_

DESCRIZIONE/DESCRIPTION/BEZEICHNUNG/DESCRIPTION/DESCRIPCIÓN  
DIMENSIONI/DIMENSIONS/ABMESSUNGEN/DIMENSIONS/DIMENSIONES

POTENZA/POWER/LEISTUNG/PUISSANCE/POTENCIA  
VOLTAGGIO/VOLTAGE/SPANNUNG/VOLTAGE/VOLTAJE

⚡ kW kcal/h  
⚡ kW V~ Hz

PREZZO/PRICE €  
PREIS/PRIX/PRECIO €  
KG / M<sup>3</sup>

**BMT-63EM**  
16050310

Bagnomaria elettrico monofase Vasca per GN 1/2 + GN 1/4 h=15  
**EN** Bain marie singlephase Bowl for GN 1/2 + GN 1/4 h=15 • **DE** Wasserbäder einphasig Becken GN 1/2 + GN 1/4 h=15 • **FR** Bain marie monophasé Cuve GN 1/2 + GN 1/4 h=15 • **ES BAÑO DE MARÍA MONOFÁSICO CUBA PARA GN 1/2 + GN 1/4 H=15**

cm. 30x 60x 28h



⚡ 1,55 kW 1.037,00  
230V~ 17 / 0,15  
50/60 Hz

**BMT-64EM**  
16050410

Bagnomaria elettrico monofase Vasca per GN 1/2 + GN 1/3 h=15  
**EN** Bain marie singlephase Bowl for GN 1/2 + GN 1/3 h=15 • **DE** Wasserbäder einphasig Becken GN 1/2 + GN 1/3 h=15 • **FR** Bain marie monophasé Cuve GN 1/2 + GN 1/3 h=15 • **ES BAÑO DE MARÍA MONOFÁSICO CUBA PARA GN 1/2 + GN 1/3 H=15**

cm. 40x 60x 28h

⚡ 1,65 kW 1.209,00  
230V~ 21 / 0,19  
50/60 Hz

**BMT-66EM**  
16050610

Bagnomaria elettrico monofase Vasca per GN 1/1 + 2 GN 1/4 h=15  
**EN** Bain marie singlephase Bowl for GN 1/1 + 2 GN 1/4 h=15 • **DE** Wasserbäder einphasig Becken GN 1/1 + 2 GN 1/4 h=15 • **FR** Bain marie monophasé Cuve GN 1/1 + 2 GN 1/4 h=15 • **ES BAÑO DE MARÍA MONOFÁSICO CUBA PARA GN 1/1 + 2 GN 1/4 H=15**

cm. 60x 60x 28h



⚡ 3,1 kW 1.338,00  
230V~ 23 / 0,28  
50/60 Hz

**BMT-64G**  
16220450

Bagnomaria a gas Vasca per GN 1/2 + GN 1/3 h=15  
**EN** Gas bain-marie Bowl for GN 1/2 + GN 1/3 h=15 • **DE** Gas Wasserbad Becken GN 1/2 + GN 1/3 h=15 • **FR** Bain-marie gaz Cuve pour GN 1/2 + GN 1/3 h=15 • **ES BAÑO DE MARÍA GAS CUBA PARA GN 1/2 + GN 1/3 H=15**

cm. 40x 60x 28h

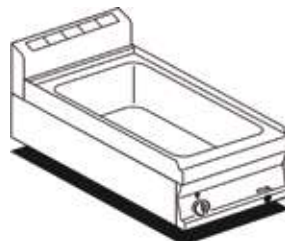

⚡ 2,5 kW 1.524,00  
2.150 kcal/h 26 / 0,19

**BMT-66G**  
16220650

Bagnomaria a gas Vasca per GN 1/1 + 2 GN 1/4 h=15  
**EN** Gas bain-marie Bowl for GN 1/1 + 2 GN 1/4 h=15 • **DE** Gas Wasserbad Becken GN 1/1 + 2 GN 1/4 h=15 • **FR** Bain-marie gaz Cuve pour GN 1/1 + 2 GN 1/4 h=15 • **ES BAÑO DE MARÍA GAS CUBA PARA GN 1/1 + 2 GN 1/4 H=15**

cm. 60x 60x 28h



⚡ 4,5 kW 1.845,00  
3.870 kcal/h 28 / 0,28

**BST-64EM**  
16040410

Contenitore caldo monofase Vasca GN 2/3 h15 con falso fondo forato  
**EN** Fry dump singlephase Bowl GN 2/3 h15 with perforated bottom • **DE** Frittenwanne einphasig Becke GN 2/3 h15 mit gelochtem Bodenrost • **FR** Silo à frites monophasé Cuve GN 2/3 h15 avec double-fond perforé • **ES RECIPIENTE CALIENTE MONOFÁSICO CUBA GN 2/3 H15 CON FALSO FONDO AGUJERADO**

cm. 40x 60x 28h



⚡ 1,47 kW 1.406,00  
230V~ 22 / 0,19  
50/60 Hz

**BRF-64ET**  
06070433

BRASIERA FISSA MULTIFUNZIONALE ELETTRICA - lt.12 Vasca cm. 30x42x10h  
**EN** Electric multi-function fixed braising pan - lt.12 Bowl cm. 30x42x10h • **DE** Elektrische Multifunktionsbratpfanne Fest - lt.12 Becken cm. 30x42x10h • **FR** Sauteuse fixe multifonction électrique - lt.12 Cuve cm. 30x42x10h • **ES SARTEN FIJA MULTIFUNCIÓN ELÉCTRICA CUBA - LT.12 CM. 30X42X10H**

cm. 40x 60x 90h



⚡ 3,3 kW 3.780,00  
400V~3N 75 / 0,37  
230V~3  
50/60 Hz

# BRASIERE FISSE MULTIFUNZIONE A GAS

MOD. \_\_\_\_\_  
COD. \_\_\_\_\_

DESCRIZIONE/DESCRIPTION/BEZEICHNUNG/DESCRIPTION/DESCRIPCIÓN  
DIMENSIONI/DIMENSIONS/ABMESSUNGEN/DIMENSIONS/DIMENSIONES

POTENZA/POWER/LEISTUNG/PUISSANCE/POTENCIA  
VOLTAGGIO/VOLTAGE/SPANNUNG/VOLTAGE/VOLTAGE

6 kW  
kcal/h

6 kW  
V~  
Hz

PREZZO/PRICE €  
PREIS/PRIX/PRECIO €  
KG / M<sup>3</sup>

**BRF-64G**  
06240453

BRASIERA FISSA MULTIFUNZIONALE GAS- Lt.12 Vasca 30x42x10h  
**EN** Gas multi-function fixed braising pan - Lt.12 Bowl 30x42x10h • **DE** Gas-Multifunktionsbratpfanne Fest - Lt.12 Becken 30x42x10h • **FR** Sauteuse fixe multifonction à gaz - Lt.12 Cuve 30x42x10h • **ES SARTEN FIJA MULTIFUNCIÓN A GAS CUBA - LT.12 30X42X10H**  
**cm. 40x 60x 90h**



6 kW  
5.160 kcal/h

**3.845,00**  
75 / 0,37

**BRT-66ET**  
16070630

Brasiera trifase - Lt. 20 Vasca cm. 50,5x41x10h  
**EN** Bratt-pan threephase - Tank capacity 20 lts. - Pan cm. 50,5x41x10 h • **DE** Bratpfanne dreiphasig - Lt. 20 - Becken cm. 50,5x41x10 h • **FR** Sauteuse triphase - Lt. 20 - Bac cm. 50,5x41x10h • **ES SARTÉN TRIFÁSICA - 20 LT. - CUBA CM. 50,5X41X10H**  
**cm. 60x 60x 28h**



6 kW  
400V~3N  
230V~3  
50/60 Hz

**1.957,00**  
45 / 0,28

**BRF-66G**  
16240650

BRASIERA GAS - Lt. 20 Vasca cm. 50,5x41x10h  
**EN** Gas bratt-pan - Capacity 20 litres - Pan cm. 50,5x41x10 h • **DE** Gas Bratpfanne - Lt. 20 - Becken cm. 50,5x41x10 h • **FR** Sauteuse gaz - Lt. 20 - Bac cm. 50,5x41x10h • **ES SARTÉN GAS - 20 L. - CUBA CM. 50,5X41X10H**  
**cm. 60x 60x 28h**



6,9 kW  
5.930 kcal/h

**2.493,00**  
46 / 0,28

**CF4-68G**  
06680850

cucina a gas 4 fuochi Forno a gas statico con grill cm. 64x39x35h, temp: 125÷275°C, con 1 griglia cm.53x32,5 GN1/1 - Porta vetro  
**EN** Gas range - N. 4 burners - Gas static oven with grill cm. 64x39x35h, temp: 125÷275°C, with 1 grid cm.53x32,5 GN1/1 - glass door • **DE** Gasherd - N. 4 Kochstellen - Gas Statischer Backofen mit grill cm. 64x39x35h, temp: 125÷275°C, mit 1 Rost cm.53x32,5 GN1/1 - Glastür • **FR** Cuisinière gaz - N. 4 feux vifs - Four gaz statique avec grill cm. 64x39x35h, temp: 125÷275°C, avec 1 grille cm.53x32,5 GN1/1 - Porte vitrée • **ES COCINA GAS - N. 4 QUEMADORES - HORNO GAS ESTÁTICO CON ASADOR CM. 64X39X35H, TEMP: 125÷275°C, CON 1 PARILLA CM.53X32,5 GN1/1 - PUERTA VIDRIO**  
**cm. 80x 60x 90h**



22 kW  
18.920 kcal/h

**3.693,00**  
97 / 0,62

0,015 kW  
230V~  
50/60 Hz

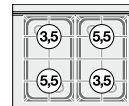

**CF4-68G**  
06680851

cucina a gas 4 fuochi Forno a gas statico con grill cm. 64x39x35h, temp: 125÷275°C, con 1 griglia cm.53x32,5 GN1/1 - Porta cieca inox  
**EN** Gas range - N. 4 burners - Gas static oven with grill cm. 64x39x35h, temp: 125÷275°C, with 1 grid cm.53x32,5 GN1/1 - Stainless steel door • **DE** Gasherd - N. 4 Kochstellen - Gas Statischer Backofen mit grill cm. 64x39x35h, temp: 125÷275°C, mit 1 Rost cm.53x32,5 GN1/1 - Edelstahltür/Porte acier inoxydable • **FR** Cuisinière gaz - N. 4 feux vifs - Four gaz statique avec grill cm. 64x39x35h, temp: 125÷275°C, avec 1 grille cm.53x32,5 GN1/1 - Porte acier inoxydable • **ES COCINA GAS - N. 4 QUEMADORES - HORNO GAS ESTÁTICO CON ASADOR CM. 64X39X35H, TEMP: 125÷275°C, CON 1 PARILLA CM.53X32,5 GN1/1 - PUERTA CIEGA INOX**  
**cm. 80x 60x 90h**



22 kW  
18.920 kcal/h

**3.693,00**  
97 / 0,62

0,015 kW  
230V~  
50/60 Hz

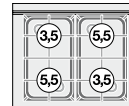

**CF6-610G**  
06681050

cucina a gas 6 fuochi Forno a gas statico con grill cm. 64x39x35h, temp: 125÷275°C, con 1 griglia cm.53x32,5 GN1/1 - Porta vetro  
**EN** Gas range - N. 6 burners - Gas static oven with grill cm. 64x39x35h, temp: 125÷275°C, with 1 grid cm.53x32,5 GN1/1 - glass door • **DE** Gasherd - N. 6 Kochstellen - Gas statischer Backofen mit grill cm. 64x39x35h, temp: 125÷275°C, mit 1 Rost cm.53x32,5 GN1/1 - Glastür • **FR** Cuisinière gaz - N. 6 feux vifs - Four gaz statique avec grill cm. 64x39x35h, temp: 125÷275°C, avec 1 grille cm.53x32,5 GN1/1 - Porte vitrée • **ES COCINA GAS - N. 6 QUEMADORES - HORNO GAS ESTÁTICO CON ASADOR CM. 64X39X35H, TEMP: 125÷275°C, CON 1 PARILLA CM.53X32,5 GN1/1 - PUERTA VIDRIO**  
**cm. 100x 60x 90h**



31 kW  
26.660 kcal/h

**3.957,00**  
106 / 0,77

0,015 kW  
230V~  
50/60 Hz

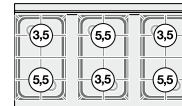

Le immagini presentate non sono vincolanti. La ditta si riserva di apportare modifiche senza preavviso. • The pictures are purely representative. The manufacturer reserves the right to modify the technical data and models without previous notice. • Les images



présentées ne nous engagent pas. La Société se réserve le droit d'apporter tout modification sans préavis. • Die dargestellten Abbildungen sind nicht verbindlich. Technische Änderungen vorbehalten. • Las imágenes presentadas no son vinculantes. El Fabricante se reserva el derecho de modificar sus productos sin previo aviso.

03/23

21

60

# CUCINE A GAS

MOD. \_\_\_\_\_  
COD. \_\_\_\_\_

DESCRIZIONE/DESCRIPTION/BEZEICHNUNG/DESCRIPTION/DESCRIPCIÓN  
DIMENSIONI/DIMENSIONS/ABMESSUNGEN/DIMENSIONS/DIMENSIONES

POTENZA/POWER/LEISTUNG/PUISSANCE/POTENCIA  
VOLTAGGIO/VOLTAGE/SPANNUNG/VOLTAGE/VOLTAJE

⚡ kW kcal/h  
⚡ kW V~ Hz

PREZZO/PRICE €  
PREIS/PRIX/PRECIO €  
KG / M<sup>3</sup>

**CF6-610G**  
06681051

cucina a gas 6 fuochi Forno a gas statico con grill cm. 64x39x35h, temp: 125÷275°C, con 1 griglia cm.53x32,5 GN1/1 - Porta cieca inox  
**EN** Gas range - N. 6 burners - Gas static oven with grill cm. 64x39x35h, temp: 125÷275°C, with 1 grid cm.53x32,5 GN1/1 - Stainless steel door  
• **DE** Gasherd - N. 6 Kochstellen - Gas statischer Backofen mit grill cm. 64x39x35h, temp: 125÷275°C, mit 1 Rost cm.53x32,5 GN1/1 - Edelstahltür/Porte acier inoxydable • **FR** Cuisinière gaz - N. 6 feux vifs - Four gaz statique avec grill cm. 64x39x35h, temp: 125÷275°C, avec 1 grille cm.53x32,5 GN1/1 - Porte acier inoxydable • **ES COCINA GAS - N. 6 QUEMADORES - HORNO GAS ESTÁTICO CON ASADOR CM. 64X39X35H, TEMP: 125÷275°C, CON 1 PARILLA CM.53X32,5 GN1/1 - PUERTA CIEGA INOX cm. 100x 60x 90h**



⚡ 31 kW 26.660 kcal/h **3.957,00**  
106 / 0,77

⚡ 0,015 kW  
230V~  
50/60 Hz

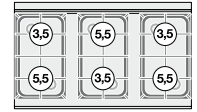

**CF4-68GEM**  
06690860

CUCINA MISTA 4 FUOCHI CON Forno elettrico statico con grill cm. 64x42x35h, temp: 50÷250°C, con 1 griglia cm.53x32,5 GN1/1 - Porta vetro  
**EN** Combined range static oven - N. 4 burners Static oven with grill cm. 64x42x35h, temp: 50÷250°C, with 1 grid cm.53x32,5 GN1/1 - Glass door • **DE** Gemischtherd statischer Ofen - N. 4 Kochstellen Statischer Ofen mit Grill cm. 64x42x35h, temp: 50÷250°C, mit 1 Rost cm.53x32,5 GN1/1 - Glasür • **FR** Cuisinière mixte gaz four statique - N. 4 feux vifs Four statique avec grill cm. 64x42x35h, temp: 50÷250°C, avec 1 grille cm.53x32,5 GN1/1 - Porte vitrée • **ES COCINA MIXTA HORNO ESTÁTICO - N. 4 QUEMADORES HORNO ESTÁTICO CON ASADOR CM. 64X42X35H, TEMP: 50÷250°C, CON 1 PARILLA CM.53X32,5 GN1/1 - PUERTA VIDRIO cm. 80x 60x 90h**



⚡ 18 kW 15.480 kcal/h **3.299,00**  
97 / 0,62

⚡ 2,62 kW  
230V~  
50/60 Hz

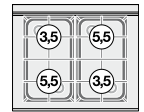

**CF4-68GEM**  
06690861

CUCINA MISTA 4 FUOCHI CON Forno elettrico statico con grill cm. 64x42x35h, temp: 50÷250°C, con 1 griglia cm.53x32,5 GN1/1 - Porta cieca inox  
**EN** Combined range static oven - N. 4 burners Static oven with grill cm. 64x42x35h, temp: 50÷250°C, with 1 grid cm.53x32,5 GN1/1 - Stainless steel door • **DE** Gemischtherd statischer Ofen - N. 4 Kochstellen Statischer Ofen mit Grill cm. 64x42x35h, temp: 50÷250°C, mit 1 Rost cm.53x32,5 GN1/1 - Edelstahltür • **FR** Cuisinière mixte gaz four estatico - N. 4 feux vifs Four statique avec grill cm. 64x42x35h, temp: 50÷250°C, avec 1 grille cm.53x32,5 GN1/1 - Porte acier inoxydable • **ES COCINA MIXTA HORNO ESTÁTICO - N. 4 QUEMADORES HORNO ESTÁTICO CON ASADOR CM. 64X42X35H, TEMP: 50÷250°C, CON 1 PARILLA CM.53X32,5 GN1/1 - PUERTA CIEGA INOX cm. 80x 60x 90h**



⚡ 18 kW 15.480 kcal/h **3.299,00**  
97 / 0,62

⚡ 2,62 kW  
230V~  
50/60 Hz

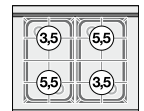

**CF6-610GEM**  
06691060

CUCINA MISTA 6 FUOCHI CON Forno elettrico statico con grill cm. 64x42x35h, temp: 50÷250°C, con 1 griglia cm.53x32,5 GN1/1 - Porta vetro  
**EN** Combined range static oven - N. 6 burners Static oven with grill cm. 64x42x35h, temp: 50÷250°C, with 1 grid cm.53x32,5 GN1/1 - Glass door • **DE** Gemischtherd statischer Ofen - N. 6 Kochstellen Statischer Ofen mit Grill cm. 64x42x35h, temp: 50÷250°C, mit 1 Rost cm.53x32,5 GN1/1 - Glasür • **FR** Cuisinière mixte gaz four statique - N. 6 feux vifs Four statique avec grill cm. 64x42x35h, temp: 50÷250°C, avec 1 grille cm.53x32,5 GN1/1 - Porte vitrée • **ES COCINA MIXTA HORNO ESTÁTICO - N. 6 QUEMADORES HORNO ESTÁTICO CON ASADOR CM. 64X42X35H, TEMP: 50÷250°C, CON 1 PARILLA CM.53X32,5 GN1/1 - PUERTA VIDRIO cm. 100x 60x 90h**



⚡ 27 kW 23.193 kcal/h **3.877,00**  
106 / 0,77

⚡ 2,62 kW  
230V~  
50/60 Hz

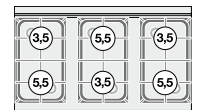

**CF6-610GEM**  
06691061

CUCINA MISTA 6 FUOCHI CON Forno elettrico statico con grill cm. 64x42x35h, temp: 50÷250°C, con 1 griglia cm.53x32,5 GN1/1 - Porta cieca inox  
**EN** Combined range static oven - N. 6 burners Static oven with grill cm. 64x42x35h, temp: 50÷250°C, with 1 grid cm.53x32,5 GN1/1 - Stainless steel door • **DE** Gemischtherd statischer Ofen - N. 6 Kochstellen Statischer Ofen mit Grill cm. 64x42x35h, temp: 50÷250°C, mit 1 Rost cm.53x32,5 GN1/1 - Edelstahltür • **FR** Cuisinière mixte gaz four estatico - N. 6 feux vifs Four statique avec grill cm. 64x42x35h, temp: 50÷250°C, avec 1 grille cm.53x32,5 GN1/1 - Porte acier inoxydable • **ES COCINA MIXTA HORNO ESTÁTICO - N. 6 QUEMADORES HORNO ESTÁTICO CON ASADOR CM. 64X42X35H, TEMP: 50÷250°C, CON 1 PARILLA CM.53X32,5 GN1/1 - PUERTA CIEGA INOX cm. 100x 60x 90h**



⚡ 27 kW 23.193 kcal/h **3.877,00**  
106 / 0,77

⚡ 2,62 kW  
230V~  
50/60 Hz

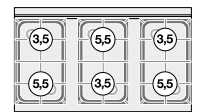

03/23  
**22**

Le immagini presentate non sono vincolanti. La ditta si riserva di apportare modifiche senza preavviso. • The pictures are purely representative. The manufacturer reserves the right to modify the technical data and models without previous notice. • Les images présentées ne nous engagent pas. La Société se réserve le

**LOTUS**

droit d'apporter tout modification sans préavis. • Die dargestellten Abbildungen sind nicht verbindlich. Technische Änderungen vorbehalten. • Las imágenes presentadas no son vinculantes. El Fabricante se reserva el derecho de modificar sus productos sin previo aviso.

**afaq**  
ISO 9001  
Qualità



# CUCINE ELETTRICHE

MOD. \_\_\_\_\_  
COD. \_\_\_\_\_

DESCRIZIONE/DESCRIPTION/BEZEICHNUNG/DESCRIPTION/DESCRIPCIÓN  
DIMENSIONI/DIMENSIONS/ABMESSUNGEN/DIMENSIONS/DIMENSIONES

POTENZA/POWER/LEISTUNG/PUISSANCE/POTENCIA  
VOLTAGGIO/VOLTAGE/SPANNUNG/VOLTAGE/VOLTAJE

⚡ kW  
kcal/h  
kw  
V~  
Hz

PREZZO/PRICE €  
PREIS/PRIX/PRECIO €  
KG / M<sup>3</sup>

**CFM4-66ET**  
06660632

CUCINA ELETTRICA TRIFASE CON 4 PIASTRE Forno elettrico multifunzione camera cm. 46x37x35h, temp: 50÷250°C, con 1 griglia cm.41x32,5 - Porta vetro  
**EN** Range threephase - N. 4 plates Multifunction electric oven Chamber cm. 46x37x35h, temp: 50÷250°C, with 1 grid cm.41x32,5 - Glass door • **DE** Elektroherd dreiphasig - N. 4 Kochplatten Multifunktions-Elektroofen - cm. 46x37x35h, temp: 50÷250°C, mit 1 Rost cm.41x32,5 - Glasstür • **FR** Cuisinière triphase - N. 4 plaques Four électrique à fonctions multiples - cm. 46x37x35h, temp: 50÷250°C, avec 1 grille cm.41x32,5 - Porte vitrée • **ES COCINA TRIFÁSICA - N. 4 PLANCHAS HORNO ELÉCTRICO MULTIFUNCIONAL - CÁMARA CM. 46X37X35H, TEMP: 50÷250 °C, CON 1 PARILLA CM.41X32,5 - PUERTA VIDRIO cm. 60x 60x 90h**



⚡ 9,05 kW  
400V~3N  
230V~3  
230V~  
50/60 Hz

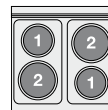

**CFM4-66ET**  
06660633

CUCINA ELETTRICA TRIFASE CON 4 PIASTRE Forno elettrico multifunzione camera cm. 46x37x35h, temp: 50÷250°C, con 1 griglia cm.41x32,5 - Porta cieca inox  
**EN** Range threephase - N. 4 plates Multifunction electric oven Chamber cm. 46x37x35h, temp: 50÷250°C, with 1 grid cm.41x32,5 - Stainless steel door • **DE** Elektroherd dreiphasig - N. 4 Kochplatten Multifunktions-Elektroofen - cm. 46x37x35h, temp: 50÷250°C, mit 1 Rost cm.41x32,5 - Edelstahlstür • **FR** Cuisinière triphase - N. 4 plaques Four électrique à fonctions multiples - cm. 46x37x35h, temp: 50÷250°C, avec 1 grille cm.41x32,5 - Porte acier inoxydable • **ES COCINA TRIFÁSICA - N. 4 PLANCHAS HORNO ELÉCTRICO MULTIFUNCIONAL - CÁMARA CM. 46X37X35H, TEMP: 50÷250 °C, CON 1 PARILLA CM.41X32,5 - PUERTA CIEGA INOX cm. 60x 60x 90h**



⚡ 9,05 kW  
400V~3N  
230V~3  
230V~  
50/60 Hz

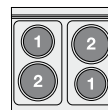

**CFM4-68ET**  
06660832

CUCINA ELETTRICA TRIFASE CON 4 PIASTRE Forno elettrico multifunzione camera cm. 64x37x35h, temp: 50÷250°C, con 1 griglia cm.53x32,5 GN1/1 - Porta vetro  
**EN** Range threephase - N. 4 plates Multifunction electric oven Chamber cm. 64x37x35h, temp: 50÷250°C, with 1 grid cm.53x32,5 GN1/1 - Glass door • **DE** Elektroherd dreiphasig - N. 4 Kochplatten Multifunktions-Elektroofen cm. 64x37x35h, temp: 50÷250°C, mit 1 Rost cm.53x32,5 GN1/1 - Glasstür • **FR** Cuisinière triphase - N. 4 plaques Four électrique à fonctions multiples cm. 64x37x35h, temp: 50÷250°C, avec 1 grille cm.53x32,5 GN1/1 - Porte vitrée • **ES COCINA TRIFÁSICA - N. 4 PLANCHAS HORNO ELÉCTRICO MULTIFUNCIONAL - CÁMARA CM. 64X37X35H, TEMP: 50÷250 °C, CON 1 PARILLA CM.53X32,5 GN1/1 - PUERTA VIDRIO cm. 80x 60x 90h**



⚡ 9,05 kW  
400V~3N  
230V~3  
230V~  
50/60 Hz



**CFM4-68ET**  
06660833

CUCINA ELETTRICA TRIFASE CON 4 PIASTRE Forno elettrico multifunzione camera cm. 64x37x35h, temp: 50÷250°C, con 1 griglia cm.53x32,5 GN1/1 - Porta cieca inox  
**EN** Range threephase - N. 4 plates Multifunction electric oven Chamber cm. 64x37x35h, temp: 50÷250°C, with 1 grid cm.53x32,5 GN1/1 - Stainless steel door • **DE** Elektroherd dreiphasig - N. 4 Kochplatten Multifunktions-Elektroofen cm. 64x37x35h, temp: 50÷250°C, mit 1 Rost cm.53x32,5 GN1/1 - Edelstahlstür • **FR** Cuisinière triphase - N. 4 plaques Four électrique à fonctions multiples cm. 64x37x35h, temp: 50÷250°C, avec 1 grille cm.53x32,5 GN1/1 - Porte acier inoxydable • **ES COCINA TRIFÁSICA - N. 4 PLANCHAS HORNO ELÉCTRICO MULTIFUNCIONAL - CÁMARA CM. 64X37X35H, TEMP: 50÷250 °C, CON 1 PARILLA CM.53X32,5 GN1/1 - PUERTA CIEGA INOX cm. 80x 60x 90h**



⚡ 9,05 kW  
400V~3N  
230V~3  
230V~  
50/60 Hz

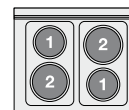

60

# CUCINE ELETTRICHE

MOD. \_\_\_\_\_  
COD. \_\_\_\_\_

DESCRIZIONE/DESCRIPTION/BEZEICHNUNG/DESCRIPTION/DESCRIPCIÓN  
DIMENSIONI/DIMENSIONS/ABMESSUNGEN/DIMENSIONS/DIMENSIONES

POTENZA/POWER/LEISTUNG/PUISSANCE/POTENCIA  
VOLTAGGIO/VOLTAGE/SPANNUNG/VOLTAGE/VOLTAJE

⚡ kW kcal/h  
V~ Hz

PREZZO/PRICE €  
PREIS/PRIX/PRECIO €  
KG / M<sup>3</sup>

**CFM6-610ET** CUCINA ELETTRICA TRIFASE CON 6 PIASTRE Forno elettrico multifunzione camera cm. 64x37x35h, temp: 50÷250°C, con 1 griglia cm.53x32,5 GN1/1 - Porta vetro

**EN** Range threephase - N. 6 plates Multifunction electric oven Chamber cm. 64x37x35h, temp: 50÷250°C, with 1 grid cm.53x32,5 GN1/1 - Glass door • **DE** Elektroherd dreiphasig - N. 6 Kochplatten Multifunktions-Elektroofen cm. 64x37x35h, temp: 50÷250°C, mit 1 Rost cm.53x32,5 GN1/1 - Glastür • **FR** Cuisinière triphase - N. 6 plaques Four électrique à fonctions multiples cm. 64x37x35h, temp: 50÷250°C, avec 1 grille cm.53x32,5 GN1/1 - Porte vitrée • **ES** **COCINA TRIFÁSICA - N. 6 PLANCHAS HORNO ELÉCTRICO MULTIFUNCIONAL - CÁMARA CM. 64X37X35H, TEMP: 50÷250°C, CON 1 PARILLA CM.53X32,5 GN1/1 - PUERTA VIDRIO**  
cm. 100x 60x 90h



⚡ 12,05 kW **4.635,00**  
400V~3N 96 / 0,77  
230V~3  
50/60 Hz

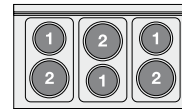

**CFM6-610ET** CUCINA ELETTRICA TRIFASE CON 6 PIASTRE Forno elettrico multifunzione camera cm. 64x37x35h, temp: 50÷250°C, con 1 griglia cm.53x32,5 GN1/1 - Porta cieca inox

**EN** Range threephase - N. 6 plates Multifunction electric oven Chamber cm. 64x37x35h, temp: 50÷250°C, with 1 grid cm.53x32,5 GN1/1 - Stainless steel door • **DE** Elektroherd dreiphasig - N. 6 Kochplatten Multifunktions-Elektroofen cm. 64x37x35h, temp: 50÷250°C, mit 1 Rost cm.53x32,5 GN1/1 - Edelstahltür • **FR** Cuisinière triphase - N. 6 plaques Four électrique à fonctions multiples cm. 64x37x35h, temp: 50÷250°C, avec 1 grille cm.53x32,5 GN1/1 - Porte acier inoxydable • **ES** **COCINA TRIFÁSICA - N. 6 PLANCHAS HORNO ELÉCTRICO MULTIFUNCIONAL - CÁMARA CM. 64X37X35H, TEMP: 50÷250°C, CON 1 PARILLA CM.53X32,5 GN1/1 - PUERTA CIEGA INOX**  
cm. 100x 60x 90h

⚡ 12,05 kW **4.635,00**  
400V~3N 96 / 0,77  
230V~3  
50/60 Hz

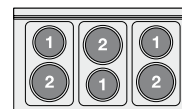

**CF4-68ET** 06660830

Cucina elettrica trifase con N. 4 piastre - Forno elettrico statico con grill cm. 64x42x35h, temp: 50÷250°C, con 1 griglia cm.53x32,5 GN1/1 - Porta vetro

**EN** Range threephase - N. 4 plates - Static oven with grill cm. 64x42x35h, temp: 50÷250°C, with 1 grid cm.53x32,5 GN1/1 - Glass door • **DE** Elektroherd dreiphasig - N. 4 Kochplatten Statischer Ofen mit Grill cm. 64x42x35h, temp: 50÷250°C, mit 1 Rost cm.53x32,5 GN1/1 - Glastür • **FR** Cuisinière triphase - N. 4 plaques - Four statique avec grill cm. 64x42x35h, temp: 50÷250°C, avec 1 grille cm.53x32,5 GN1/1 - Porte vitrée • **ES** **COCINA TRIFÁSICA - N. 4 PLANCHAS - HORNO ESTÁTICO CON ASADOR CM. 64X42X35H, TEMP: 50÷250°C, CON 1 PARILLA CM.53X32,5 GN1/1 - PUERTA VIDRIO**  
cm. 80x 60x 90h



⚡ 8,62 kW **2.955,00**  
400V~3N 91 / 0,62  
230V~3  
230V~  
50/60 Hz

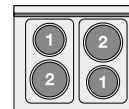

**CF4-68ET** 06660831

Cucina elettrica trifase con N. 4 piastre - Forno elettrico statico con grill cm. 64x42x35h, temp: 50÷250°C, con 1 griglia cm.53x32,5 GN1/1 - Porta cieca inox

**EN** Range threephase - N. 4 plates - Static oven with grill cm. 64x42x35h, temp: 50÷250°C, with 1 grid cm.53x32,5 GN1/1 - Stainless steel door • **DE** Elektroherd dreiphasig - N. 4 Kochplatten Statischer Ofen mit Grill cm. 64x42x35h, temp: 50÷250°C, mit 1 Rost cm.53x32,5 GN1/1 - Edelstahltür • **FR** Cuisinière triphase - N. 4 plaques - Four statique avec grill cm. 64x42x35h, temp: 50÷250°C, avec 1 grille cm.53x32,5 GN1/1 - Porte acier inoxydable • **ES** **COCINA TRIFÁSICA - N. 4 PLANCHAS - HORNO ESTÁTICO CON ASADOR CM. 64X42X35H, TEMP: 50÷250°C, CON 1 PARILLA CM.53X32,5 GN1/1 - PUERTA CIEGA INOX**  
cm. 80x 60x 90h



⚡ 8,62 kW **2.955,00**  
400V~3N 91 / 0,62  
230V~3  
230V~  
50/60 Hz

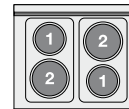

# CUCINE ELETTRICHE

MOD. \_\_\_\_\_  
COD. \_\_\_\_\_

DESCRIZIONE/DESCRIPTION/BEZEICHNUNG/DESCRIPTION/DESCRIPCIÓN  
DIMENSIONI/DIMENSIONS/ABMESSUNGEN/DIMENSIONS/DIMENSIONES

POTENZA/POWER/LEISTUNG/PUISSANCE/POTENCIA  
VOLTAGGIO/VOLTAGE/SPANNUNG/VOLTAGE/VOLTAJE

⚡ 11,62 kW  
400V~3N  
230V~3  
50/60 Hz

PREZZO/PRICE €  
PREIS/PRIX/PRECIO €  
KG / M<sup>3</sup>

**CF6-610ET**  
06661030

Cucina elettrica trifase con N. 6 piastre - Forno elettrico statico con grill cm. 64x42x35h, temp: 50÷250°C, con 1 griglia cm.53x32,5 GN1/1 - Porta vetro  
**EN** Range threephase - N. 6 plates - Static oven with grill cm. 64x42x35h, temp: 50÷250°C, with 1 grid cm.53x32,5 GN1/1 - Glass door • **DE** Elektroherd dreiphasig - N. 6 Kochplatten Statischer Ofen mit Grill cm. 64x42x35h, temp: 50÷250°C, mit 1 Rost cm.53x32,5 GN1/1 - Glasstür • **FR** Cuisinière triphase - N. 6 plaques - Four statique avec grill cm. 64x42x35h, temp: 50÷250°C, avec 1 grille cm.53x32,5 GN1/1 - Porte vitrée • **ES COCINA TRIFÁSICA - N. 6 PLANCHAS - HORNO ESTÁTICO CON ASADOR CM. 64X42X35H, TEMP: 50÷250 °C, CON 1 PARILLA CM.53X32,5 GN1/1 - PUERTA VIDRIO**  
**cm. 100x 60x 90h**



⚡ 11,62 kW  
400V~3N  
230V~3  
50/60 Hz

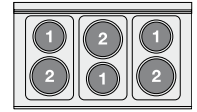

**CF6-610ET**  
06661031

Cucina elettrica trifase con N. 6 piastre - Forno elettrico statico con grill cm. 64x42x35h, temp: 50÷250°C, con 1 griglia cm.53x32,5 GN1/1 - Porta cieca inox  
**EN** Range threephase - N. 6 plates - Static oven with grill cm. 64x42x35h, temp: 50÷250°C, with 1 grid cm.53x32,5 GN1/1 - Stainless steel door • **DE** Elektroherd dreiphasig - N. 6 Kochplatten Statischer Ofen mit Grill cm. 64x42x35h, temp: 50÷250°C, mit 1 Rost cm.53x32,5 GN1/1 - Edelstahlstür • **FR** Cuisinière triphase - N. 6 plaques - Four statique avec grill cm. 64x42x35h, temp: 50÷250°C, avec 1 grille cm.53x32,5 GN1/1 - Porte acier inoxydable • **ES COCINA TRIFÁSICA - N. 6 PLANCHAS - HORNO ESTÁTICO CON ASADOR CM. 64X42X35H, TEMP: 50÷250 °C, CON 1 PARILLA CM.53X32,5 GN1/1 - PUERTA CIEGA INOX**  
**cm. 100x 60x 90h**

⚡ 11,62 kW  
400V~3N  
230V~3  
50/60 Hz



**CFM4-66GEM**  
06690662

CUCINA MISTA 4 FUOCHI CON Forno elettrico multifunzione - Camera cm. 46x37x35h, temp: 50÷250°C, con 1 griglia cm.41x32,5 - Porta vetro  
**EN** Combined range - N. 4 burners Multifunction oven - Chamber cm. 46x37x35h, temp: 50÷250°C, with 1 grid cm.41x32,5 - Glass door • **DE** Gemischtherd - N. 4 Kochstellen Multifunktions-Ofen - cm. 46x37x35h, temp: 50÷250°C, mit 1 Rost cm.41x32,5 - Glasstür • **FR** Cuisinière mixte - N. 4 feux vifs Four à fonctions multiples - cm. 46x37x35h, temp: 50÷250°C, avec 1 grille cm.41x32,5 - Porte vitrée • **ES COCINA MIXTA - N. 4 QUEMADORES HORNO MULTIFUNCIONAL - CÁMARA CM. 46X37X35H, TEMP: 50÷250 °C, CON 1 PARILLA CM.41X32,5 - PUERTA VIDRIO**  
**cm. 60x 60x 90h**



⚡ 18 kW  
15.480 kcal/h

⚡ 3,05 kW  
230V~  
50/60 Hz

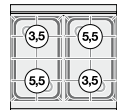

**CFM4-66GEM**  
06690663

CUCINA MISTA 4 FUOCHI CON Forno elettrico multifunzione - Camera cm. 46x37x35h, temp: 50÷250°C, con 1 griglia cm.41x32,5 - Porta cieca inox  
**EN** Combined range - N. 4 burners Multifunction oven - Chamber cm. 46x37x35h, temp: 50÷250°C, with 1 grid cm.41x32,5 - Stainless steel door • **DE** Gemischtherd - N. 4 Kochstellen Multifunktions-Ofen - cm. 46x37x35h, temp: 50÷250°C, mit 1 Rost cm.41x32,5 - Edelstahlstür • **FR** Cuisinière mixte - N. 4 feux vifs Four à fonctions multiples - cm. 46x37x35h, temp: 50÷250°C, avec 1 grille cm.41x32,5 - Porte acier inoxydable • **ES COCINA MIXTA - N. 4 QUEMADORES HORNO MULTIFUNCIONAL - CÁMARA CM. 46X37X35H, TEMP: 50÷250 °C, CON 1 PARILLA CM.41X32,5 - PUERTA CIEGA INOX**  
**cm. 60x 60x 90h**



⚡ 18 kW  
15.480 kcal/h

⚡ 3,05 kW  
230V~  
50/60 Hz

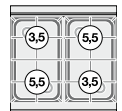

**CFM4-68GEM**  
06690862

CUCINA MISTA 4 FUOCHI CON Forno elettrico multifunzione - Camera cm. 64x37x35h, temp: 50÷250°C, con 1 griglia cm.53x32,5 GN1/1 - Porta vetro  
**EN** Combined range - N. 4 burners Multifunction oven - Chamber cm. 64x37x35h, temp: 50÷250°C, with 1 grid cm.53x32,5 GN1/1 - Glass door • **DE** Gemischtherd - N. 4 Kochstellen Multifunktions-Ofen cm. 64x37x35h, temp: 50÷250°C, with 1 grid cm.53x32,5 GN1/1 - Glasstür • **FR** Cuisinière mixte - N. 4 feux vifs Four à fonctions multiples cm. 64x37x35h, temp: 50÷250°C, avec 1 grille cm.53x32,5 GN1/1 - Porte vitrée • **ES COCINA MIXTA - N. 4 QUEMADORES HORNO MULTIFUNCIONAL - CÁMARA CM. 64X37X35H, TEMP: 50÷250 °C, CON 1 PARILLA CM.53X32,5 GN1/1 - PUERTA VIDRIO**  
**cm. 80x 60x 90h**



⚡ 18 kW  
15.480 kcal/h

⚡ 3,05 kW  
230V~  
50/60 Hz

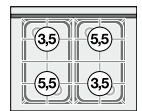

# CUCINE A GAS CON FORNO ELETTRICO

MOD. \_\_\_\_\_  
COD. \_\_\_\_\_

DESCRIZIONE/DESCRIPTION/BEZEICHNUNG/DESCRIPTION/DESCRIPCIÓN  
DIMENSIONI/DIMENSIONS/ABMESSUNGEN/DIMENSIONS/DIMENSIONES

POTENZA/POWER/LEISTUNG/PUISSANCE/POTENCIA  
VOLTAGGIO/VOLTAGE/SPANNUNG/VOLTAGE/VOLTAJE

⚡ kW \_\_\_\_\_  
kcal/h \_\_\_\_\_  
⚡ kW \_\_\_\_\_  
V~ \_\_\_\_\_  
Hz \_\_\_\_\_

PREZZO/PRICE € \_\_\_\_\_  
PREIS/PRIX/PRECIO € \_\_\_\_\_  
KG / M<sup>3</sup> \_\_\_\_\_

**CFM4-68GEM** CUCINA MISTA 4 FUOCHI CON Forno elettrico multifunzione - Camera cm. 64x37x35h, temp: 50÷250°C, con 1 griglia cm.53x32,5 GN1/1 - Porta cieca inox

**EN** Combined range - N. 4 burners Multifunction oven - Chamber cm. 64x37x35h, temp: 50÷250°C, with 1 grid cm.53x32,5 GN1/1 - Stainless steel door • **DE** Gemischtherd - N. 4 Kochstellen Multifunktions-Ofen cm. 64x37x35h, temp: 50÷250°C, with 1 grid cm.53x32,5 GN1/1 - Edelstahltür • **FR** Cuisinière mixte - N. 4 feux vifs Four à fonctions multiples cm. 64x37x35h, temp: 50÷250°C, avec 1 grille cm.53x32,5 GN1/1 - Porte acier inoxydable • **ES COCINA MIXTA - N. 4 QUEMADORES HORNO MULTIFUNCIONAL - CÁMARA CM. 64X37X35H, TEMP: 50÷250°C, CON 1 PARILLA CM.53X32,5 GN1/1 - PUERTA CIEGA INOX cm. 80x 60x 90h**



⚡ 18 kW \_\_\_\_\_ **4.818,00**  
15.480 kcal/h 98 / 0,62

⚡ 3,05 kW \_\_\_\_\_  
230V~ \_\_\_\_\_  
50/60 Hz \_\_\_\_\_

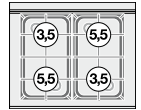

**CFM6-610GEM** CUCINA MISTA 6 FUOCHI CON Forno elettrico multifunzione - Camera cm. 64x37x35h, temp: 50÷250°C, con 1 griglia cm.53x32,5 GN1/1 - Porta vetro

**EN** Combined range - N. 6 burners Multifunction oven - Chamber cm. 64x37x35h, temp: 50÷250°C, with 1 grid cm.53x32,5 GN1/1 - Glass door • **DE** Gemischtherd - N. 6 Kochstellen Multifunktions-Ofen cm. 64x37x35h, temp: 50÷250°C, mit 1 Rost cm.53x32,5 GN1/1 - Glastür • **FR** Cuisinière mixte - N. 6 feux vifs Four à fonctions multiples cm. 64x37x35h, temp: 50÷250°C, avec 1 grille cm.53x32,5 GN1/1 - Porte vitrée • **ES COCINA MIXTA - N. 6 QUEMADORES HORNO MULTIFUNCIONAL - CÁMARA CM. 64X37X35H, TEMP: 50÷250°C, CON 1 PARILLA CM.53X32,5 GN1/1 - PUERTA VIDRIO cm. 100x 60x 90h**



⚡ 27 kW \_\_\_\_\_ **5.390,00**  
23.193 kcal/h 107 / 0,77

⚡ 3,05 kW \_\_\_\_\_  
230V~ \_\_\_\_\_  
50/60 Hz \_\_\_\_\_

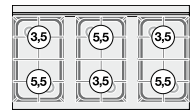

**CFM6-610GEM** CUCINA MISTA 6 FUOCHI CON Forno elettrico multifunzione - Camera cm. 64x37x35h, temp: 50÷250°C, con 1 griglia cm.53x32,5 GN1/1 - Porta cieca inox

**EN** Combined range - N. 6 burners Multifunction oven - Chamber cm. 64x37x35h, temp: 50÷250°C, with 1 grid cm.53x32,5 GN1/1 - Stainless steel door • **DE** Gemischtherd - N. 6 Kochstellen Multifunktions-Ofen cm. 64x37x35h, temp: 50÷250°C, mit 1 Rost cm.53x32,5 GN1/1 - Edelstahltür • **FR** Cuisinière mixte - N. 6 feux vifs Four à fonctions multiples cm. 64x37x35h, temp: 50÷250°C, avec 1 grille cm.53x32,5 GN1/1 - Porte acier inoxydable • **ES COCINA MIXTA - N. 6 QUEMADORES HORNO MULTIFUNCIONAL - CÁMARA CM. 64X37X35H, TEMP: 50÷250°C, CON 1 PARILLA CM.53X32,5 GN1/1 - PUERTA CIEGA INOX cm. 100x 60x 90h**



⚡ 27 kW \_\_\_\_\_ **5.390,00**  
23.193 kcal/h 107 / 0,77

⚡ 3,05 kW \_\_\_\_\_  
230V~ \_\_\_\_\_  
50/60 Hz \_\_\_\_\_

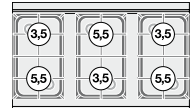

**TPF4-610G** TUTTA PIASTRA + 4 fuochi Forno a gas statico con grill cm. 64x39x35h, temp: 125÷275°C, con 1 griglia cm.53x32,5 GN1/1 - Piastra cm. 37x50 - Porta vetro

**EN** Solid top + 4 burners on Gas static oven with grill cm. 64x39x35h, temp: 125÷275°C, with 1 grid cm.53x32,5 GN1/1, Plate cm. 37x50 - Glass door • **DE** Kochplatte + 4 Gaskochstellen auf Gas statischer Backofen mit grill cm. 64x39x35h, temp: 125÷275°C, mit 1 Rost cm.53x32,5 GN1/1 Platte cm. 37x50 - Glastür • **FR** Toute plaque + 4 brûleurs sur Four gaz statique avec grill cm. 64x39x35h, temp: 125÷275°C, avec 1 grille cm.53x32,5 GN1/1 Plaque cm. 37x50 - Porte vitrée • **ES PLACA DE COCCIÓN + 4 FUEGOS CON HORNO GAS ESTÁTICO CON ASADOR CM. 64X39X35H, TEMP: 125÷275°C, CON 1 PARILLA CM.53X32,5 GN1/1, PLACA CM. 37X50 - PUERTA VIDRIO cm. 100x 60x 90h**



⚡ 27,5 kW \_\_\_\_\_ **5.443,00**  
23.650 kcal/h 165 / 0,77

⚡ 0,015 kW \_\_\_\_\_  
230V~ \_\_\_\_\_  
50/60 Hz \_\_\_\_\_

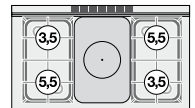

**TPF4-610G** TUTTA PIASTRA + 4 fuochi Forno a gas statico con grill cm. 64x39x35h, temp: 125÷275°C, con 1 griglia cm.53x32,5 GN1/1 - Piastra cm. 37x50 - Porta cieca inox

**EN** Solid top + 4 burners on Gas static oven with grill cm. 64x39x35h, temp: 125÷275°C, with 1 grid cm.53x32,5 GN1/1, Plate cm. 37x50 - Stainless steel door • **DE** Kochplatte + 4 Gaskochstellen auf Gas statischer Backofen mit grill cm. 64x39x35h, temp: 125÷275°C, mit 1 Rost cm.53x32,5 GN1/1 Platte cm. 37x50 - Edelstahltür • **FR** Toute plaque + 4 brûleurs sur Four gaz statique avec grill cm. 64x39x35h, temp: 125÷275°C, avec 1 grille cm.53x32,5 GN1/1 Plaque cm. 37x50 - Porte acier inoxydable • **ES PLACA DE COCCIÓN + 4 FUEGOS CON HORNO GAS ESTÁTICO CON ASADOR CM. 64X39X35H, TEMP: 125÷275°C, CON 1 PARILLA CM.53X32,5 GN1/1, PLACA CM. 37X50 - PUERTA CIEGA INOX cm. 100x 60x 90h**



⚡ 27,5 kW \_\_\_\_\_ **5.443,00**  
23.650 kcal/h 165 / 0,77

⚡ 0,015 kW \_\_\_\_\_  
230V~ \_\_\_\_\_  
50/60 Hz \_\_\_\_\_

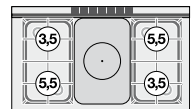



# TUTTAPIASTRA A GAS CON FORNO ELETTRICO

MOD. \_\_\_\_\_  
COD. \_\_\_\_\_

DESCRIZIONE/DESCRIPTION/BEZEICHNUNG/DESCRIPTION/DESCRIPCIÓN  
DIMENSIONI/DIMENSIONS/ABMESSUNGEN/DIMENSIONS/DIMENSIONES

POTENZA/POWER/LEISTUNG/PUISSANCE/POTENCIA  
VOLTAGGIO/VOLTAGE/SPANNUNG/VOLTAGE/VOLTAJE

⚡ kW  
kcal/h

⚡ kW  
V~  
Hz

PREZZO/PRICE €  
PREIS/PRIX/PRECIO €  
KG / M<sup>3</sup>

**TPF4-610GEM** TUTTA PIASTRA + 4 FUOCHI CON Forno elettrico statico - camera cm. 64x42x35h, temp: 50÷250°C, con 1 griglia cm.53x32,5 GN1/1 - Piastra cm. 37x50 - Porta vetro

**EN** Solid top + 4 burners Traditional electric oven - chamber cm 64x42x35h, temp: 50÷250°C, with 1 grid cm.53x32,5 GN1/1, Plate cm. 37x50 - Glass door • **DE** Kochplatte + 4 Gaskochstellen Statischer elektro-backofen cm. 64x42x35h, temp: 50÷250°C, mit 1 Rost cm.53x32,5 GN1/1 Platte cm. 37x50 - Glastür • **FR** Toute plaque + 4 brûleurs vifs Four électrique statique chambre cm.64x42x35h, temp: 50÷250°C, avec 1 grille cm.53x32,5 GN1/1 Plaque cm. 37x50 - Porte vitrée • **ES PLACA DE COCCIÓN + 4 FUEGOS HORNO ELÉCTRICO ESTÁTICO CÁMARA CM. 64X42X35H, TEMP: 50÷250°C, CON 1 PARILLA CM.53X32,5 GN1/1, PLACA CM. 37X50 - PUERTA VIDRIO cm. 100x 60x 90h**



⚡ 23,5 kW **5.195,00**  
20.210 kcal/h 165 / 0,77

⚡ 2,62 kW  
230V~  
50/60 Hz

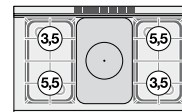

**TPF4-610GEM** TUTTA PIASTRA + 4 FUOCHI CON Forno elettrico statico - camera cm. 64x42x35h, temp: 50÷250°C, con 1 griglia cm.53x32,5 GN1/1 - Piastra cm. 37x50 - Porta cieca inox

**EN** Solid top + 4 burners Traditional electric oven - chamber cm 64x42x35h, temp: 50÷250°C, with 1 grid cm.53x32,5 GN1/1, Plate cm. 37x50 - Stainless steel door • **DE** Kochplatte + 4 Gaskochstellen Statischer elektro-backofen cm. 64x42x35h, temp: 50÷250°C, mit 1 Rost cm.53x32,5 GN1/1 Platte cm. 37x50 - Edelstahltür • **FR** Toute plaque + 4 brûleurs vifs Four électrique statique chambre cm.64x42x35h, temp: 50÷250°C, avec 1 grille cm.53x32,5 GN1/1 Plaque cm. 37x50 - Porte acier inoxydable • **ES PLACA DE COCCIÓN + 4 FUEGOS HORNO ELÉCTRICO ESTÁTICO CÁMARA CM. 64X42X35H, TEMP: 50÷250°C, CON 1 PARILLA CM.53X32,5 GN1/1, PLACA CM. 37X50 - PUERTA CIEGA INOX cm. 100x 60x 90h**



⚡ 23,5 kW **5.195,00**  
20.210 kcal/h 165 / 0,77

⚡ 2,62 kW  
230V~  
50/60 Hz

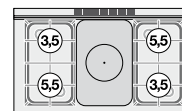

**TPFM4-610GEM** TUTTA PIASTRA + 4 FUOCHI CON Forno elettrico multifunzione cm. 64x37x35h, temp: 50÷250°C, con 1 griglia cm.53x32,5 GN1/1 - Piastra cm. 37x50 - Porta vetro

**EN** Solid top + 4 burners Multifunction electric oven cm. 64x37x35h, temp: 50÷250°C, with 1 grid cm.53x32,5 GN1/1, Plate cm. 37x50 - Glass door • **DE** Kochplatte + 4 Gaskochstellen Multifunktions-Elektroofen cm. 64x37x35h, temp: 50÷250°C, mit 1 Rost cm.53x32,5 GN1/1 Platte cm. 37x50 - Glastür • **FR** Toute plaque + 4 brûleurs vifs Four électrique à fonctions multiples cm. 64x37x35h, temp: 50÷250°C, avec 1 grille cm.53x32,5 GN1/1 Plaque cm. 37x50 - Porte vitrée • **ES PLACA DE COCCIÓN + 4 FUEGOS HORNO ELÉCTRICO MULTIFUNCIONAL CM. 64X37X35H, TEMP: 50÷250°C, CON 1 PARILLA CM.53X32,5 GN1/1, PLACA CM. 37X50 - PUERTA VIDRIO cm. 100x 60x 90h**



⚡ 23,5 kW **6.699,00**  
20.210 kcal/h 166 / 0,77

⚡ 3,05 kW  
230V~  
50/60 Hz

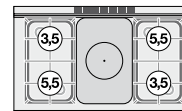

**TPFM4-610GEM** TUTTA PIASTRA + 4 FUOCHI CON Forno elettrico multifunzione cm. 64x37x35h, temp: 50÷250°C, con 1 griglia cm.53x32,5 GN1/1 - Piastra cm. 37x50 - Porta cieca inox

**EN** Solid top + 4 burners Multifunction electric oven cm. 64x37x35h, temp: 50÷250°C, with 1 grid cm.53x32,5 GN1/1, Plate cm. 37x50 - Stainless steel door • **DE** Kochplatte + 4 Gaskochstellen Multifunktions-Elektroofen cm. 64x37x35h, temp: 50÷250°C, mit 1 Rost cm.53x32,5 GN1/1 Platte cm. 37x50 - Edelstahltür • **FR** Toute plaque + 4 brûleurs vifs Four électrique à fonctions multiples cm. 64x37x35h, temp: 50÷250°C, avec 1 grille cm.53x32,5 GN1/1 Plaque cm. 37x50 - Porte acier inoxydable • **ES PLACA DE COCCIÓN + 4 FUEGOS HORNO ELÉCTRICO MULTIFUNCIONAL CM. 64X37X35H, TEMP: 50÷250°C, CON 1 PARILLA CM.53X32,5 GN1/1, PLACA CM. 37X50 - PUERTA CIEGA INOX cm. 100x 60x 90h**



⚡ 23,5 kW **6.699,00**  
20.210 kcal/h 166 / 0,77

⚡ 3,05 kW  
230V~  
50/60 Hz

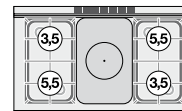

# CUCINE ELETTRICHE

MOD. \_\_\_\_\_  
COD. \_\_\_\_\_

DESCRIZIONE/DESCRIPTION/BEZEICHNUNG/DESCRIPTION/DESCRIPCIÓN  
DIMENSIONI/DIMENSIONS/ABMESSUNGEN/DIMENSIONS/DIMENSIONES

POTENZA/POWER/LEISTUNG/PUISSANCE/POTENCIA  
VOLTAGGIO/VOLTAGE/SPANNUNG/VOLTAGE/VOLTAJE

⚡ kW kcal/h  
V~ Hz

PREZZO/PRICE €  
PREIS/PRIX/PRECIO  
KG / M<sup>3</sup>

**CFMC4-66ET** CUCINA CON PIANO IN VETROCERAMICA Vetro cm. 58x44 Forno multifunzione - Camera cm. 46x37x35h, temp: 50÷250°C, con 1 griglia cm.41x32,5 - Porta vetro  
**EN** Range threephase - Ceramic, Glass: cm. 58x44 Multifunction oven - Chamber cm. 46x37x35h, temp: 50÷250°C, with 1 grid cm.41x32,5 - Glass door • **DE** Elektroherd dreiphasing - Ceran-Kochfläche cm. 58x44 Multifunktions-Ofen - cm. 46x37x35h, temp: 50÷250°C, mit 1 Rost cm.41x32,5 - Glastür • **FR** Cuisinière triphase - Vitrocéramique Plaque cm. 58x44 Four à fonctions multiples - cm. 46x37x35h, temp: 50÷250°C, avec 1 grille cm.41x32,5 - Porte vitrée • **ES COCINA TRIFASICA - PLACA VITROCERÁMICA, CRISTAL CM. 58X44 HORNO MULTIFUNCIONAL - CÁMARA CM. 46X37X35H, TEMP: 50÷250°C, CON 1 PARILLA CM.41X32,5 - PUERTA VIDRIO cm. 60x 60x 90h**



⚡ 9,05 kW 5.000,00  
400V~3N 70 / 0,47  
230V~3  
230V~  
50/60 Hz

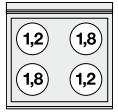

**CFMC4-66ET** CUCINA CON PIANO IN VETROCERAMICA Vetro cm. 58x44 Forno multifunzione - Camera cm. 46x37x35h, temp: 50÷250°C, con 1 griglia cm.41x32,5 - Porta cieca inox  
**EN** Range threephase - Ceramic, Glass: cm. 58x44 Multifunction oven - Chamber cm. 46x37x35h, temp: 50÷250°C, with 1 grid cm.41x32,5 - Stainless steel door • **DE** Elektroherd dreiphasing - Ceran-Kochfläche cm. 58x44 Multifunktions-Ofen - cm. 46x37x35h, temp: 50÷250°C, mit 1 Rost cm.41x32,5 - Edelstahltür • **FR** Cuisinière triphase - Vitrocéramique Plaque cm. 58x44 Four à fonctions multiples - cm. 46x37x35h, temp: 50÷250°C, avec 1 grille cm.41x32,5 - Porte acier inoxyddable • **ES COCINA TRIFASICA - PLACA VITROCERÁMICA, CRISTAL CM. 58X44 HORNO MULTIFUNCIONAL - CÁMARA CM. 46X37X35H, TEMP: 50÷250°C, CON 1 PARILLA CM.41X32,5 - PUERTA CIEGA INOX cm. 60x 60x 90h**



⚡ 9,05 kW 5.000,00  
400V~3N 70 / 0,47  
230V~3  
230V~  
50/60 Hz

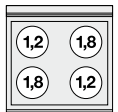

**PT2/3-CFM66** Portateglie GN 2/3, per CFM-66  
**EN** Frame for oven plates GN 2/3, for CFM-66 • **DE** Aufangeschienen für Backbleche GN 2/3 für CFM-66 • **FR** Kit porte-plaques GN 2/3 pour CFM-66 • **ES PORTACAZUELAS GN2/3 PARA CFM-66**



98,00  
5 / 0,02

**CF2-68G** cucina a gas 2 fuochi Forno a gas statico con grill cm. 67x38x34h, temp: 125÷275°C, con 1 griglia cm.65x36  
**EN** Gas range - N. 2 burners - Gas static oven with grill cm. 67x38x34h, temp: 125÷275°C, with 1 grid cm.65x36 • **DE** Gasherd - N. 2 Kochstellen - Gas statischer Backofen mit Grill cm. 67x38x34h, temp: 125÷275°C, mit 1 Rost cm.65x36 • **FR** Forneau gaz - N. 2 feux vifs - Four a gaz statique avec grill cm. 67x38x34h, temp: 125÷275°C, avec 1 grille cm.65x36 • **ES COCINA GAS - N. 2 QUEMADORES HORNO A GAS ESTÁTICO CON ASADOR CM. 67X38X34H, TEMP: 125÷275°C, CON 1 PARILLA CM.65X36 cm. 80x 60x 90h**



⚡ 21 kW 4.054,00  
18.060 kcal/h 95 / 0,62

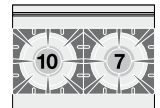

**CF2-68GEM** CUCINA MISTA 2 FUOCHI CON Forno elettrico statico con grill cm. 67x38x34h, temp: 50÷250°C, con 1 griglia cm.65x36  
**EN** Combined range static oven - N. 2 burners Static oven cm. 67x38x34h, temp: 50÷250°C, with 1 grid cm.65x36 • **DE** Gemischtherd statischer Ofen - N. 2 Kochstellen Statischer Ofen cm. 67x38x34h, temp: 50÷250°C, mit 1 Rost cm.65x36 • **FR** Cuisinière mixte gaz four estático - N. 2 feux vifs Four statique cm. 67x38x34h, temp: 50÷250°C, avec 1 grille cm.65x36 • **ES COCINA MIXTA HORNO ESTÁTICO - N. 2 QUEMADORES HORNO ESTÁTICO CM. 67X38X34H, TEMP: 50÷250°C, CON 1 PARILLA CM.65X36 cm. 80x 60x 90h**



⚡ 17 kW 4.128,00  
14.620 kcal/h 95 / 0,62

⚡ 3,05 kW  
230V~  
50/60 Hz

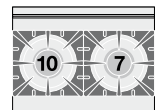

# CUCINE A GAS CON FORNO ELETTRICO

MOD. \_\_\_\_\_  
COD. \_\_\_\_\_

DESCRIZIONE/DESCRIPTION/BEZEICHNUNG/DESCRIPTION/DESCRIPCIÓN  
DIMENSIONI/DIMENSIONS/ABMESSUNGEN/DIMENSIONS/DIMENSIONES

POTENZA/POWER/LEISTUNG/PUISSANCE/POTENCIA  
VOLTAGGIO/VOLTAGE/SPANNUNG/VOLTAGE/VOLTAJE

kW kcal/h  
V~ Hz

PREZZO/PRICE €  
PREIS/PRIX/PRECIO €  
KG / M<sup>3</sup>

**CFM2-68GEM** CUCINA MISTA 2 FUOCHI CON Forno elettrico multifunzione cm. 64x37x35h, temp: 50÷250°C, con 1 griglia cm.53x32,5 GN1/1 - Porta vetro  
06790862  
**EN** Combined range - N. 2 burners Multifunction electric oven cm. 64x37x35h, temp: 50÷250°C, with 1 grid cm.53x32,5 GN1/1 - Glass door • **DE** Gemischtherd - N. 2 Kochstellen Multifunktions-Elektroofen cm. 64x37x35h, temp: 50÷250°C, mit 1 Rost cm.53x32,5 GN1/1 - Glastür • **FR** Cuisinière mixte - N. 2 feux vifs Four électrique à fonctions multiples cm. 64x37x35h, temp: 50÷250°C, avec 1 grille cm.53x32,5 GN1/1 - Porte acier inoxydable • **ES COCINA MIXTA - N. 2 QUEMADORES HORNO ELÉCTRICO MULTIFUNCIONAL CM. 64X37X35H, TEMP: 50÷250 °C, CON 1 PARILLA CM.53X32,5 GN1/1 - PUERTA CIEGA INOX cm. 80x 60x 90h**



17 kW 4.531,00  
14.620 kcal/h 96 / 0,62

3,05 kW  
230V~  
50/60 Hz

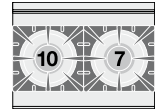

**CFM2-68GEM** CUCINA MISTA 2 FUOCHI CON Forno elettrico multifunzione cm. 64x37x35h, temp: 50÷250°C, con 1 griglia cm.53x32,5 GN1/1 - Porta cieca inox  
06790863  
**EN** Combined range - N. 2 burners Multifunction electric oven cm. 64x37x35h, temp: 50÷250°C, with 1 grid cm.53x32,5 GN1/1 - Stainless steel door • **DE** Gemischtherd - N. 2 Kochstellen Multifunktions-Elektroofen cm. 64x37x35h, temp: 50÷250°C, mit 1 Rost cm.53x32,5 GN1/1 - Edelstahltür • **FR** Cuisinière mixte - N. 2 feux vifs Four électrique à fonctions multiples cm. 64x37x35h, temp: 50÷250°C, avec 1 grille cm.53x32,5 GN1/1 - Porte acier inoxydable • **ES COCINA MIXTA - N. 2 QUEMADORES HORNO ELÉCTRICO MULTIFUNCIONAL CM. 64X37X35H, TEMP: 50÷250 °C, CON 1 PARILLA CM.53X32,5 GN1/1 - PUERTA CIEGA INOX cm. 80x 60x 90h**



17 kW 4.531,00  
14.620 kcal/h 96 / 0,62

3,05 kW  
230V~  
50/60 Hz

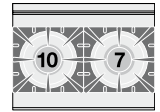

**CF3-612GV** cucina a gas 3 fuochi Forno a gas statico con grill cm. 67x38x34h, temp: 125÷275°C, con 1 griglia cm.65x36, vano neutro con porta.  
06781251  
**EN** Gas range - N. 3 burners - Gas static oven with grill cm. 67x38x34h, temp: 125÷275°C, with 1 grid cm.65x36 - Neutral cabinet with door • **DE** Gasherd - N. 3 Kochstellen - Gas statischer Backofen mit Grill cm. 67x38x34h, temp: 125÷275°C, mit 1 Rost cm.65x36 - Neutrales Schrankelement mit Tür • **FR** Forneau gaz - N. 3 feux vifs - Four a gaz statique avec grill cm. 67x38x34h, temp: 125÷275°C, avec 1 grille cm.65x36 - Element neutre avec porte • **ES COCINA GAS - N. 3 QUEMADORES HORNO A GAS ESTÁTICO CON ASADOR CM. 67X38X34H, TEMP: 125÷275 °C, CON 1 PARILLA CM.65X36 - ARMARIO NEUTRO CON PUERTA EQUIPADO cm. 120x 60x 90h**



31 kW 4.968,00  
26.660 kcal/h 102 / 0,92

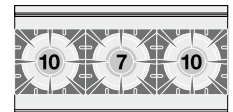

**CF3-612GEMV** CUCINA MISTA 3 FUOCHI CON Forno elettrico statico con grill cm. 67x38x34h, temp: 50÷250°C, con 1 griglia cm.65x36, vano neutro con porta  
06791261  
**EN** Combined range static oven - N. 3 burners Static oven cm. 67x38x34h, temp: 50÷250°C, with 1 grid cm.65x36 - Neutral cabinet with door • **DE** Gemischtherd statischer Ofen - N. 3 Kochstellen Statischer Ofen cm. 67x38x34h, temp: 50÷250°C, mit 1 Rost cm.65x36 - Neutrales Schrankelement mit Tür • **FR** Cuisinière mixte gaz four estatico - N. 3 feux vifs Four statique cm. 67x38x34h, temp: 50÷250°C, avec 1 grille cm.65x36 - Element neutre avec porte • **ES COCINA MIXTA HORNO ESTÁTICO - N. 3 QUEMADORES HORNO ESTÁTICO CM. 67X38X34H, TEMP: 50÷250 °C, CON 1 PARILLA CM.65X36 - ARMARIO NEUTRO CON PUERTA EQUIPADO cm. 120x 60x 90h**



27 kW 5.058,00  
23.220 kcal/h 102 / 0,92

3,05 kW  
230V~  
50/60 Hz

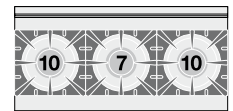

**CFM3-612GEMV** CUCINA MISTA 3 FUOCHI CON Forno elettrico multifunzione cm. 64x37x35h, temp: 50÷250°C, con 1 griglia cm.53x32,5 GN1/1 - Porta vetro - vano neutro con porta  
06791262  
**EN** Combined range - N. 3 burners Multifunction electric oven cm. 64x37x35h, temp: 50÷250°C, with 1 grid cm.53x32,5 GN1/1 - Glass door - Neutral cabinet with door • **DE** Gemischtherd - N. 3 Kochstellen Multifunktions-Elektroofen cm. 64x37x35h, temp: 50÷250°C, mit 1 Rost cm.53x32,5 GN1/1 - Glastür - Neutrales Schrankelement mit Tür • **FR** Cuisinière mixte - N. 3 feux vifs Four électrique à fonctions multiples cm. 64x37x35h, temp: 50÷250°C, avec 1 grille cm.53x32,5 GN1/1 - Porte acier inoxydable - Element neutre avec porte • **ES COCINA MIXTA - N. 3 QUEMADORES HORNO ELÉCTRICO MULTIFUNCIONAL CM. 64X37X35H, TEMP: 50÷250 °C, CON 1 PARILLA CM.53X32,5 GN1/1 - PUERTA CIEGA INOX - ARMARIO NEUTRO CON PUERTA EQUIPADO cm. 120x 60x 90h**



27 kW 5.433,00  
23.220 kcal/h 103 / 0,92

3,05 kW  
230V~  
50/60 Hz

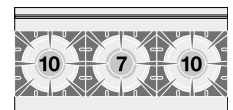

Le immagini presentate non sono vincolanti. La ditta si riserva di apportare modifiche senza preavviso. • The pictures are purely representative. The manufacturer reserves the right to modify the technical data and models without previous notice. • Les images



présentées ne nous engagent pas. La Société se réserve le droit d'apporter tout modification sans préavis. • Die dargestellten Abbildungen sind nicht verbindlich. Technische Änderungen vorbehalten. • Las imágenes presentadas no son vinculantes. El Fabricante se reserva el derecho de modificar sus productos sin previo aviso.

03/23

29

# CUCINE A GAS CON FORNO ELETTRICO

MOD. \_\_\_\_\_  
COD. \_\_\_\_\_

DESCRIZIONE/DESCRIPTION/BEZEICHNUNG/DESCRIPTION/DESCRIPCIÓN  
DIMENSIONI/DIMENSIONS/ABMESSUNGEN/DIMENSIONS/DIMENSIONES

POTENZA/POWER/LEISTUNG/PUISSANCE/POTENCIA  
VOLTAGGIO/VOLTAGE/SPANNUNG/VOLTAGE/VOLTAJE

⚡ kW  
23.220 kcal/h

PREZZO/PRICE €  
KG / M<sup>3</sup>

**CFM3-612GEMV** CUCINA MISTA 3 FUOCHI CON Forno elettrico multifunzione cm. 64x37x35h, temp: 50÷250°C, con 1 griglia cm.53x32,5 GN1/1 - Porta cieca inox - vano neutro con porta  
**EN** Combined range - N. 3 burners Multifunction electric oven cm. 64x37x35h, temp: 50÷250°C, with 1 grid cm.53x32,5 GN1/1 - Stainless steel door - Neutral cabinet with door • **DE** Gemischtherd - N. 3 Kochstellen Multifunktions-Elektroofen cm. 64x37x35h, temp: 50÷250°C, mit 1 Rost cm.53x32,5 GN1/1 - Edelstahltür - Neutrales Schrankelement mit Tür • **FR** Cuisinière mixte - N. 3 feux vifs Four électrique à fonctions multiples cm. 64x37x35h, temp: 50÷250°C, avec 1 grille cm.53x32,5 GN1/1 - Porte acier inoxydable - Element neutre avec porte • **ES** **COCINA MIXTA - N. 3 QUEMADORES HORNO ELÉCTRICO MULTIFUNCIONAL CM. 64X37X35H, TEMP: 50÷250 °C, CON 1 PARILLA CM.53X32,5 GN1/1 - PUERTA CIEGA INOX - ARMARIO NEUTRO CON PUERTA EQUIPADO cm. 120x 60x 90h**



⚡ 27 kW  
23.220 kcal/h

**5.433,00**  
103 / 0,92

⚡ 3,05 kW  
230V~  
50/60 Hz

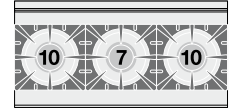

**CPT-64ET** CUOCIPASTA TRIFASE LT. 17 Vasca cm. 31x33,5x22h. Rubinetto scarico (CESTI ESCLUSI)  
**EN** Pasta cooker threephase 17 lts. Tank cm. 31x33,5x22h. Drain-tap (BASKETS EXCLUDED) • **DE** Nudelkocher dreiphasig lt.17 Becken cm. 31x33,5x22h. Ablasshahn (KORB AUSGESCHLOSSEN) • **FR** Cuiseur à pâtes triphase lt.17 Cuve cm. 31x33,5x22h. Robinet de vidange (PANIERS EXCLUS) • **ES** **CUECE PASTA TRIFÁSICO LT.17 CUBA CM. 31X33,5X22H. GRIFO DESCARGA (CESTAS EXCLUIDAS) cm. 40x 60x 28h**



⚡ 4,1 kW  
400V~3N  
230V~  
50/60 Hz

**1.921,00**  
27 / 0,19

## COMBINAZIONI

- Combinations / • Zusammenstellungen
- Combinaisons / • Combinación múltiple



**CPT-66ET** CUOCIPASTA TRIFASE LT. 25 Vasca cm. 51x31x22h. Rubinetto scarico (CESTI ESCLUSI)  
**EN** Pasta cooker threephase 25 lts. Tank cm. 51x31x22h. Drain-tap (BASKETS EXCLUDED) • **DE** Nudelkocher dreiphasig lt.25 Becken cm. 51x31x22h. Ablasshahn (KORB AUSGESCHLOSSEN) • **FR** Cuiseur à pâtes triphase lt.25 Cuve cm. 51x31x22h. Robinet de vidange (PANIERS EXCLUS) • **ES** **CUECE PASTA TRIFÁSICO LT.25 CUBA CM. 51X31X22H. GRIFO DESCARGA (CESTAS EXCLUIDAS) cm. 60x 60x 28h**



⚡ 6,25 kW  
400V~3N  
50/60 Hz

**2.134,00**  
42 / 0,28

## COMBINAZIONI

- Combinations / • Zusammenstellungen
- Combinaisons / • Combinación múltiple



**CPT-64G** CUOCIPASTA A GAS CAPACITA' LT. 13 Vasca cm. 31x33,5x18h. Rubinetto scarico (CESTI ESCLUSI)  
**EN** Gas pasta cookers Tank capacity 13 lts. Tank cm. 31x33,5x18h. Drain-tap (BASKETS EXCLUDED) • **DE** Gas -Nudelkocher Beckeninhalte lt.13 Becken cm. 31x33,5x18h. Ablasshahn (KORB AUSGESCHLOSSEN) • **FR** Cuiseur à pâtes gaz Cuve lt.13 Cuve cm. 31x33,5x18h. Robinet de vidange (PANIERS EXCLUS) • **ES** **CUECE PASTA GAS CUBA 13 LT. CUBA CM. 31X33,5X18H. GRIFO DESCARGA (CESTAS EXCLUIDAS) cm. 40x 60x 28h**



⚡ 6 kW  
5.160 kcal/h

**1.950,00**  
30 / 0,19

## COMBINAZIONI

- Combinations / • Zusammenstellungen
- Combinaisons / • Combinación múltiple



# CUOCIPASTA A GAS - TOP

MOD. \_\_\_\_\_  
COD. \_\_\_\_\_

DESCRIZIONE/DESCRIPTION/BEZEICHNUNG/DESCRIPTION/DESCRIPCIÓN  
DIMENSIONI/DIMENSIONS/ABMESSUNGEN/DIMENSIONS/DIMENSIONES

POTENZA/POWER/LEISTUNG/PUISSANCE/POTENCIA  
VOLTAGGIO/VOLTAGE/SPANNUNG/VOLTAGE/VOLTAJE

⚡ kW  
kcal/h

⚡ kW  
V~  
Hz

PREZZO/PRICE €  
PREIS/PRIX/PRECIO €  
KG / M<sup>3</sup>

**CPT-66G**  
16270650

CUOCIPASTA A GAS CAPACITA' LT. 19 Vasca cm. 51x31x18h. Rubinetto scarico (CESTI ESCLUSI)

**EN** Gas pasta cookers Tank capacity 19 lts. Tank cm. 51x31x18h. Drain-tap (BASKETS EXCLUDED) • **DE** Gas -Nudelkocher Beckeninhalt lt. 19 Becken cm. 51x31x18h. Ablasshahn (KORB AUSGESCHLOSSEN) • **FR** Cuiseur à pâtes gaz Cuve lt.19 Cuve cm. 51x31x18h. Robinet de vidange (PANIERS EXCLUS) • **ES CUECE PASTA GAS CUBA 19 LT. CUBA CM. 51X31X18H. GRIFO DESCARGA (CESTAS EXCLUIDAS) cm. 60x 60x 28h**



⚡ 9 kW  
7.740 kcal/h

**2.296,00**  
45 / 0,28

### COMBINAZIONI

- Combinations / • Zusammenstellungen
- Combinaisons / • Combinación múltiple



**CP-66ET**  
06100630

CUOCIPASTA TRIFASE LT. 40 Vasca cm. 51x30,7x32,7h. Rubinetto carico acqua, sfioratore + scarico a pavimento (CESTI ESCLUSI)

**EN** Pasta cooker threephase 40 lts. - Tank cm. 51x30,7x32,7h. Water loading tap + overflow device and floor draining (BASKETS EXCLUDED) • **DE** Nudelkocher dreiphasig lt. 40 - Becken cm. 51x30,7x32,7h. Wasserlauf-Hahn + Überlauf-Vorrichtung und Ablauf am Boden (KORB AUSGESCHLOSSEN) • **FR** Cuiseur à pâtes triphase lt. 40 - Cuve cm. 51x30,7x32,7h. Robinet d'arrivée d'eau trop plein + système de vidange au sol (PANIERS EXCLUS) • **ES CUECE PASTA TRIFÁSICO LT. 40 - CUBA CM. 51 X30,7X32,7H. GRIFO CARGA AGUA + VERTEDERO + DESCARGA A PAVIMENTO (CESTAS EXCLUIDAS) cm. 60x 60x 90h**



⚡ 13,5 kW  
400V~3N  
50/60 Hz

**3.718,00**  
81 / 0,47

### COMBINAZIONI

- Combinations / • Zusammenstellungen
- Combinaisons / • Combinación múltiple



**CPA-66ET**  
06100635

CUOCIPASTA TRIFASE LT. 40 Vasca cm. 51x30,7x32,7h. Carico acqua automatico con sensore di livello - sfioratore + scarico a pavimento (CESTI ESCLUSI)

**EN** Pasta cooker threephase 40 lts. - Tank cm. 51x30,7x32,7h. - Automatic Water loading with level sensor - overflow device and floor draining (BASKETS EXCLUDED) • **DE** Nudelkocher dreiphasig lt. 40 - Becken cm. 51x30,7x32,7h. Automatische Wasser Beladung mit Niveauregulierung + Überlauf-Vorrichtung und Ablauf am Boden (KORB AUSGESCHLOSSEN) • **FR** Cuiseur à pâtes triphase lt. 40 - Cuve cm. 51x30,7x32,7h. Chargement automatique de l'eau avec sensor de niveau, trop plein Système de vidange au sol (PANIERS EXCLUS) • **ES CUECE PASTA TRIFÁSICO LT. 40 - CUBA CM. 51 X30,7X32,7H. CARGA AUTOMÁTICA DE AGUA CON SENSOR DE NIVEL + VERTEDERO + DESCARGA A PAVIMENTO. (CESTAS EXCLUIDAS) cm. 60x 60x 90h**



⚡ 13,5 kW  
400V~3N  
50/60 Hz

**4.225,00**  
82 / 0,47

### COMBINAZIONI

- Combinations / • Zusammenstellungen
- Combinaisons / • Combinación múltiple



60

# CUOCIPASTA A GAS

MOD. \_\_\_\_\_  
COD. \_\_\_\_\_

DESCRIZIONE/DESCRIPTION/BEZEICHNUNG/DESCRIPTION/DESCRIPCIÓN  
DIMENSIONI/DIMENSIONS/ABMESSUNGEN/DIMENSIONS/DIMENSIONES

POTENZA/POWER/LEISTUNG/PUISSANCE/POTENCIA  
VOLTAGGIO/VOLTAGE/SPANNUNG/VOLTAGE/VOLTAJE

⚡ kW kcal/h  
⚡ kW V~ Hz

PREZZO/PRICE €  
PREIS/PRIX/PRECIO €  
KG / M<sup>3</sup>

**CP-66G**  
06270650

CUOCIPASTA GAS LT. 40 Vasca cm. 51x30,7x32,7h. Rubinetto carico acqua, sfioratore + scarico a pavimento (CESTI ESCLUSI)  
**EN** Gas pasta cooker on cabinet Tank capacity 40 lts. cm. 51x30,7x32,7h. Water loading tap + overflow device and floor draining (BASKETS EXCLUDED) • **DE** Gas-Nudelkocher Standgerät - Inhalt lt. 40 cm. 51x30,7x32,7h. Wasserlauf-Hahn + Überlauf-Vorrichtung und Ablauf am Boden (KORB AUSGESCHLOSSEN) • **FR** Cuiseur a pates sur coffre gaz - Cuve lt. 40 cm. 51x30,7x32,7h. Robinet d'arrivée d'eau trop plein + système de vidange au sol (PANIERS EXCLUS) • **ES CUECE PASTA GAS - CUBA 40 LT. CM. 51X30,7X32,7H. GRIFO CARGA AGUA + VERTEDERO + DESCARGA A PAVIMENTO (CESTAS EXCLUIDAS)**  
cm. 60x 60x 90h



⚡ 13,95 kW 4.141,00  
11.997 kcal/h 84 / 0,47  
⚡ 0,02 KW  
230V~  
50/60 Hz

## COMBINAZIONI

- Combinations / • Zusammenstellungen
- Combinaisons / • Combinación múltiple



**CPA-66G**  
06270655

CUOCIPASTA GAS LT. 40 Vasca cm. 51x30,7x32,7h. Carico acqua automatico con sensore di livello - sfioratore + scarico a pavimento (CESTI ESCLUSI)  
**EN** Gas pasta cooker on cabinet Tank capacity 40 lts. cm. 51x30,7x32,7h. Automatic Water loading with level sensor - overflow device and floor draining (BASKETS EXCLUDED) • **DE** Gas-Nudelkocher Standgerät - Inhalt lt. 40 cm. 51x30,7x32,7h. Automatische Wasser Beladung mit Niveauregulierung + Überlauf-Vorrichtung und Ablauf am Boden (KORB AUSGESCHLOSSEN) • **FR** Cuiseur a pates sur coffre gaz - Cuve lt. 40 cm. 51x30,7x32,7h. Chargement automatique de l'eau avec sensor de niveau, trop plein Système de vidange au sol (PANIERS EXCLUS) • **ES CUECE PASTA GAS - CUBA 40 LT. CM. 51X30,7X32,7H. CARGA AUTOMÁTICA DE AGUA CON SENSOR DE NIVEL + VERTEDERO + DESCARGA A PAVIMENTO. (CESTAS EXCLUIDAS)**  
cm. 60x 60x 90h



⚡ 13,95 kW 4.427,00  
11.997 kcal/h 85 / 0,47  
⚡ 0,035 KW  
230V~  
50/60 Hz

## COMBINAZIONI

- Combinations / • Zusammenstellungen
- Combinaisons / • Combinación múltiple



**CWKT-64ET**  
16080431

GRIGLIA CONTACT - cottura diretta su resistenza in acciaio inox cm. 27x35 ribaltabile  
**EN** CONTACT Grill threephase - Stainless steel grill cm. 27x35 • **DE** Wurstbrater dreiphasig KONTAKT - Einstellbarer Rost aus Nirosta cm. 27x35 • **FR** Grillade triphase CONTACT - Grille inox cm 27x35 • **ES PARRILLA TRIFÁSICO CONTACT - PARRILLA DE ACERO INOX REGULABLE CM 27X35**  
cm. 40x 60x 28h



⚡ 3,36 kW 2.810,00  
400V~3N 35 / 0,19  
50/60 Hz

**CWKT-68ET**  
16080831

GRIGLIA CONTACT - cottura diretta su resistenza in acciaio inox cm. 55x35 ribaltabile  
**EN** CONTACT Grill threephase - Stainless steel grill cm. 55x35 • **DE** Wurstbrater dreiphasig KONTAKT - Einstellbarer Rost aus Nirosta cm. 55x35 • **FR** Grillade triphase CONTACT - Grille inox cm 55x35 • **ES PARRILLA TRIFÁSICO CONTACT - PARRILLA DE ACERO INOX REGULABLE CM 55X35**  
cm. 80x 60x 28h

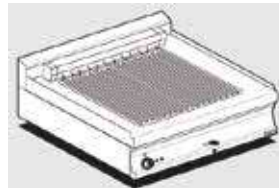

⚡ 6,72 kW 3.776,00  
400V~3N 50 / 0,37  
50/60 Hz

# GRIGLIE ELETTRICHE - TOP

MOD. \_\_\_\_\_  
COD. \_\_\_\_\_

DESCRIZIONE/DESCRIPTION/BEZEICHNUNG/DESCRIPTION/DESCRIPCIÓN  
DIMENSIONI/DIMENSIONS/ABMESSUNGEN/DIMENSIONS/DIMENSIONES

POTENZA/POWER/LEISTUNG/PUISSANCE/POTENCIA  
VOLTAGGIO/VOLTAGE/SPANNUNG/VOLTAGE/VOLTAGE

⚡ kW kcal/h  
⚡ kW V~ Hz

PREZZO/PRICE €  
PREIS/PRIX/PRECIO €  
KG / M<sup>3</sup>

**CWT-64ET**  
16080430

Griglia elettrica trifase Griglia in acciaio inox cm. 38x42,5 regolabile  
**EN** Grill threephase - Stainless steel grill cm. 38x42,5 • **DE** Wurstbrater dreiphasig Einstellbarer Rost aus Nirosta cm. 38x42,5 • **FR** Grillade Triphase - Grille inox cm. 38x42,5 • **ES PARRILLA TRIFÁSICO PARRILLA DE ACERO INOX REGULABLE CM. 38X42,5 cm. 40x 60x 28h**



⚡ 4,8 kW 1.976,00  
400V~3N 36 / 0,19  
230V~3  
50/60 Hz

**CWT-66ET**  
16080630

Griglia elettrica trifase Griglia in acciaio inox cm. 58x42,5 regolabile  
**EN** Grill threephase - Stainless steel grill cm. 58x42,5 • **DE** Wurstbrater dreiphasig Einstellbarer Rost aus Nirosta cm. 58x42,5 • **FR** Grillade Triphase - Grille inox cm. 58x42,5 • **ES PARRILLA TRIFÁSICO PARRILLA DE ACERO INOX REGULABLE CM. 58X42,5 cm. 60x 60x 28h**



⚡ 6,3 kW 2.247,00  
400V~3N 48 / 0,28  
230V~3  
50/60 Hz

**CWT-68ET**  
16080830

Griglia elettrica trifase N. 2 griglie in acciaio inox cm. 38x42,5 regolabili  
2 zone di cottura  
**EN** Grill threephase - N. 2 Stainless steel grill cm. 38x42,5 2 cooking areas • **DE** Wurstbrater dreiphasig - N. 2 einstellbarer Rost aus Nirosta cm. 38x42,5 - 2 Heizzonen • **FR** Grillade Triphase - N. 2 grilles réglables en acier inox cm. 38x42,5 - 2 zones de cuisson • **ES PARRILLA TRIFÁSICO - N. 2 PARRILLAS DE ACERO INOX REGULABLE CM. 38X42,5 - 2 ZONAS DE COCCIÓN cm. 80x 60x 28h**



⚡ 9,6 kW 3.057,00  
400V~3N 52 / 0,37  
230V~3  
50/60 Hz

**CWT-64G**  
16250450

Griglia a gas-pietralavica Griglia in acciaio inox cm. 38x42,5 regolabile  
**EN** Charcoal grill gas - Stainless steel grill cm. 38x42,5 • **DE** Gas-Lavasteingrill - Einstellbarer Rost aus Nirosta cm. 38x42,5 • **FR** Grille à gaz en pierre de lave - Grille inox cm. 38x42,5 • **ES PARRILLA A GAS PIEDRA LÁVICA PARRILLA DE ACERO INOX REGULABLE CM. 38X42,5 cm. 40x 60x 28h**



⚡ 5,8 kW 2.065,00  
4.988 kcal/h 41 / 0,19

**CWT-66G**  
16250650

Griglia a gas-pietralavica Griglia in acciaio inox cm. 58x42,5 regolabile  
**EN** Charcoal grill gas - Stainless steel grill cm. 58x42,5 • **DE** Gas-Lavasteingrill - Einstellbarer Rost aus Nirosta cm. 58x42,5 • **FR** Grille à gaz en pierre de lave - Grille inox cm. 58x42,5 • **ES PARRILLA A GAS PIEDRA LÁVICA PARRILLA DE ACERO INOX REGULABLE CM. 58X42,5 cm. 60x 60x 28h**



⚡ 8,9 kW 2.474,00  
7.654 kcal/h 58 / 0,28

**CWT-68G**  
16250850

Griglia a gas-pietralavica N. 2 griglie in acciaio inox cm. 38x42,5 regolabili - 2 zone di cottura  
**EN** Charcoal grill gas N. 2 Stainless steel grill cm. 38x42,5 - 2 cooking areas • **DE** Gas-Lavasteingrill N. 2 einstellbarer Rost aus Nirosta cm. 38x42,5 - Heizzonen • **FR** Grille à gaz en pierre de lave N. 2 grilles réglables en acier inox cm. 38x42,5 - 2 zones de cuisson • **ES PARRILLA A GAS PIEDRA LÁVICA N. 2 PARRILLAS DE ACERO INOX REGULABLE CM. 38X42,5 - 2 ZONAS DE COCCIÓN cm. 80x 60x 28h**



⚡ 11,6 kW 3.325,00  
9.976 kcal/h 62 / 0,37

60

# FRIGGITRICI ELETTRICHE - TOP

MOD. \_\_\_\_\_  
COD. \_\_\_\_\_

DESCRIZIONE/DESCRIPTION/BEZEICHNUNG/DESCRIPTION/DESCRIPCIÓN  
DIMENSIONI/DIMENSIONS/ABMESSUNGEN/DIMENSIONS/DIMENSIONES

POTENZA/POWER/LEISTUNG/PUISSANCE/POTENCIA  
VOLTAGGIO/VOLTAGE/SPANNUNG/VOLTAGE/VOLTAJE

⚡ kW  
kcal/h

⚡ kW  
V~  
Hz

PREZZO/PRICE €  
PREIS/PRIX/PRECIO €  
KG / M<sup>3</sup>

**F10T-63EM**  
16090310

Friggitrice elettrica monofase - Vasca lt. 10 cm. 22x35x23h Con filtro e coperchio - Cesto cm. 20x30x10h Produzione patate 8 kg/h  
**EN** Fryer singlephase - Tank capacity 10 Lst. cm. 22x35x23h - Sieve and lid for pan - Basket cm. 20x30x10h - Production 8 kg/hr • **DE** Friteuse einphasig - Beckeninhalte lt. 10 cm. 22x35x23h - Einlegesieb und Deckel für Becken - Korb cm. 20x30x10h Pommes frites: 8 kg/pro Stunde • **FR** Friteuse monophasé - Cuve lt. 10 cm. 22x35x23h - Filtre, couvercle pour cuve - Panier 20x30x10h Production de pommes frites: 8 kg/h • **ES FREIDORA MONOFÁSICA - CUBA 10 LT CM. 22X35X23H - FILTRO Y TAPA PARA CUBA - CESTA CM. 20X30X10H PRODUCCIÓN PATATAS 8 KG/H**  
**cm. 30x 60x 28h**



⚡ 3,65 kW **1.318,00**  
230V~ 20 / 0,15  
50/60 Hz

**F10T-63ET**  
16090330

Friggitrice elettrica trifase - Vasca Lt. 10 cm. 22x35x23h Con filtro e coperchio - Cesto cm. 20x30x10h Produzione patate 10 kg/h  
**EN** Fryer threephase - Tank capacity 10 Lst. cm. 22x35x23h - Sieve and lid for pan - Basket cm. 20x30x10h - Production 10 kg/hr • **DE** Friteuse dreiphasing - Beckeninhalte lt. 10 cm. 22x35x23h - Einlegesieb und Deckel für Becken - Korb cm. 20x30x10h - Pommes frites: 10 kg/pro Stunde • **FR** Friteuse triphase - Cuve lt. 10 cm. 22x35x23h - Filtre, couvercle pour cuve - Panier 20x30x10h Production de pommes frites: 10 kg/h • **ES FREIDORA TRIFÁSICA - CUBA 10 LT CM. 22X35X23H - FILTRO Y TAPA PARA CUBA - CESTA CM. 20X30X10H PRODUCCIÓN PATATAS 10 KG/H**  
**cm. 30x 60x 28h**

⚡ 7,15 kW **1.526,00**  
400V~3N 21 / 0,15  
230V~3  
50/60 Hz

**F2/10T-66ET**  
16090630

Friggitrice elettrica trifase - Vasche Lt. 10+10 cm. 22x35x23h Con filtro e coperchio - N. 2 cesti cm. 20x30x10h Produzione patate 20 kg/h  
**EN** Fryer threephase - Tank capacity 10+10 Lst. cm. 22x35x23h - Sieve and lid for pan - N. 2 baskets cm. 20x30x10h - Production 20 kg/hr • **DE** Friteuse dreiphasing - Beckeninhalte lt. 10+10cm. 22x35x23h - Einlegesieb und Deckel für Becken - N. 2 Korbe cm. 20x30x10h - Pommes frites: 20 kg/pro Stunde • **FR** Friteuse triphase - Cuves lt. 10+10 cm. 22x35x23h - Filtre, couvercle pour cuve - N. 2 paniers 20x30x10h Production de pommes frites: 20 kg/h • **ES FREIDORA TRIFÁSICA - CUBA 10+10 LT. CM. 22X35X23H - FILTRO Y TAPA PARA CUBA - N. 2 CESTAS CM. 20X30X10H PRODUCCIÓN PATATAS 20 KG/H**  
**cm. 60x 60x 28h**



⚡ 14,3 kW **2.700,00**  
400V~3N 37 / 0,28  
230V~3  
50/60 Hz

**F2/10T-66EM**  
16090610

Friggitrice elettrica monofase - Vasche Lt. 10+10 cm. 22x35x23h Con filtro e coperchio - N. 2 cesti cm. 20x30x10h Produzione patate 16 kg/h  
**EN** Fryer singlephase - Tank capacity 10+10 Lst. cm. 22x35x23h - Sieve and lid for pan - N. 2 baskets cm. 20x30x10h Production 16 kg/hr • **DE** Friteuse einphasig - Beckeninhalte lt. 10+10cm. 22x35x23h - Einlegesieb und Deckel für Becken - N. 2 Korbe cm. 20x30x10h Pommes frites: 16 kg/pro Stunde • **FR** Friteuse monophasé - Cuves lt. 10+10 cm. 22x35x23h - Filtre, couvercle pour cuve - N. 2 paniers 20x30x10h Production de pommes frites: 16 kg/h • **ES FREIDORA MONOFÁSICA - CUBA 10+10 LT. CM. 22X35X23H - FILTRO Y TAPA PARA CUBA - N. 2 CESTAS CM. 20X30X10H PRODUCCIÓN PATATAS 16 KG/H**  
**cm. 60x 60x 28h**

⚡ 7,3 kW **2.289,00**  
230V~ 34 / 0,28  
50/60 Hz

**F8T-63G**  
16260350

Friggitrice a gas - Vasca Lt. 8 cm. 22x27,5x22h - Con filtro e coperchio - cesto 20x24x9h - Produzione patate: 8 kg/h  
**EN** Gas fryer - Tank capacity 8 lts. cm. 22x27,5x22h - Basket cm. 20x24x9h - Production: 8kg/h • **DE** Gas-einzelfriteuse - Beckeninhalte lt. 8 cm. 22x27,5x22h - Korb cm. 20x24x9h - Pommes frites: 8 kg/pro Stunde • **FR** Friteuse gaz - Cuve lt. 8 cm. 22x27,5x22h - Panier 20x24x9h Production de pommes frites: 8 kg/h • **ES FREIDORA GAS - CUBA 8 LT. CM. 22X27,5X22H - CESTA CM. 20X24X9H PRODUCCIÓN PATATAS: 8 KG/H**  
**cm. 30x 60x 28h**



⚡ 6 kW **1.826,00**  
5.160 kcal/h 23 / 0,15



# FRIGGITRICI A GAS - TOP

MOD. \_\_\_\_\_  
COD. \_\_\_\_\_

DESCRIZIONE/DESCRIPTION/BEZEICHNUNG/DESCRIPTION/DESCRIPCIÓN  
DIMENSIONI/DIMENSIONS/ABMESSUNGEN/DIMENSIONS/DIMENSIONES

POTENZA/POWER/LEISTUNG/PUISSANCE/POTENCIA  
VOLTAGGIO/VOLTAGE/SPANNUNG/VOLTAGE/VOLTAJE

⚡ kW  
kcal/h

PREZZO/PRICE €  
PREIS/PRIX/PRECIO €  
KG / M<sup>3</sup>

**F2/8T-66G**  
16260650

Friggitrice a gas - Vasche Lt. 8+8 cm. 22x27,5x22h - Con filtro e coperchio - N. 2 cesti 20x24x9h - Produzione patate: 16 kg/h  
**EN** Gas fryer - Tank capacity 8+8 lts. cm. 22x27,5x22h - N. 2 baskets cm. 20x24x9h Production: 16 kg/h • **DE** Gas-einzelfriteuse - Beckeninhalt lt. 8+8 cm. 22x27,5x22h - N. 2 Korbe cm. 20x24x9h Pommes frites: 16 kg/pro Stunde • **FR** Friteuse gaz - Cuve lt. 8+8 cm. 22x27,5x22h - N. 2 paniers 20x24x9h - Production de pommes frites: 16 kg/h • **ES FREIDORA GAS - CUBA 8+8 LT. CM. 22X27,5X22H - N. 2 CESTAS CM. 20X24X9H PRODUCCIÓN PATATAS: 16 KG/H**  
**cm. 60x 60x 28h**



⚡ 12 kW  
10.320 kcal/h

**3.171,00**  
41 / 0,28

**F13-64ET**  
06090430

FRIGGITRICE TRIFASE LT. 13 Vasca cm. 24x35x32h - 1 cesto cm. 21x30x12h - Filtro e coperchio vasca. Bacinella raccogliolio con filtro. - Produzione patate: 10 kg/h  
**EN** Fryer threephase 13 lts - Bowl cm. 24x35x32h - 1 basket cm. 21x30x12h. Sieve and lid for pan. - Drip tray with sieve. Production: 10 kg/h • **DE** Friteuse dreiphasig lt. 13 - Becken cm. 24x35x32h - 1 Korb cm. 21x30x12h. Einlegesieb und Deckel für Becken. - Fettauffangschale mit Sieb. Pommes frites: 10 kg/h • **FR** Friteuse triphase lt. 13 - Cuve cm. 24x35x32h - 1 Panier cm. 21x30x12h. Filtre, couvercle pour cuve. - Bac de récupération de l'huile avec filtre. Production de pommes frites: 10 kg/h • **ES FREIDORAS TRIFÁSICO 13 LT. - CUBA CM. 24X35X32H - 1 CESTA CM. 21X30X12H. FILTRO Y TAPA PARA CUBA. BANDEJA RECOGE ACEITE CON FILTRO. PROD. PATATAS: 10 KG/H**  
**cm. 40x 60x 90h**



⚡ 10,95 kW  
400V~3N  
50/60 Hz

**2.584,00**  
52 / 0,37

**F13-64G**  
06260450

Friggitrice gas LT. 13 Vasca cm. 32,5x31,5x36h - 1 cesto cm. 30x27,5x12h - Filtro e coperchio vasca. Bacinella raccogliolio con filtro. - Produzione patate: 10 kg/h  
**EN** Gas fryer 13 lts - Bowl cm. 32,5x31,5x36h - 1 basket cm. 30x27,5x12h. Sieve and lid for pan. - Drip tray with sieve. Production: 10 kg/h • **DE** Gas-Friteuse lt. 13 - Becken cm. 32,5x31,5x36h - 1 Korb cm. 30x27,5x12h. Einlegesieb und Deckel für Becken. - Fettauffangschale mit Sieb. Pommes frites: 10 kg/h • **FR** Friteuse a gaz lt. 13 - Cuve cm. 32,5x31,5x36h - 1 Panier cm. 30x27,5x12h. Filtre, couvercle pour cuve. - Bac de récupération de l'huile avec filtre. Production de pommes frites: 10 kg/h • **ES FREIDORAS A GAS 13 LT. - CUBA CM. 32,5X31,5X36H - 1 CESTA CM. 30X27,5X12H. FILTRO Y TAPA PARA CUBA. BANDEJA RECOGE ACEITE CON FILTRO. PROD. PATATAS: 10 KG/H**  
**cm. 40x 60x 90h**



⚡ 10,5 kW  
9.020 kcal/h

**2.914,00**  
60 / 0,37

**FTLT-64ET**  
16060431

Fry-top elettrico liscio, piastra cm.39,5x45  
**EN** Electric Fry-top smooth griddle, plate cm.39,5x45 • **DE** Griddleplatte elektrische glatt, platte cm.39,5x45 • **FR** Plaque électriques lisse, plaque cm.39,5x45 • **ES FRY-TOP ELÉCTRICO LISO, PLANCHA CM.39,5X45**  
**cm. 40x 60x 28h**



⚡ 4,5 kW  
400V~3N  
230V~3  
50/60 Hz

**1.417,00**  
49 / 0,19

**FTLT-64ETS**  
16060434

Fry-top elettrico liscio cromato SUPERCHROME (Moca Approved), piastra cm.39,5x45  
**EN** Electric Fry-top smooth chromed griddle SUPERCHROME (Moca Approved), plate cm.39,5x45 • **DE** Griddleplatte elektrische glatt hartverchromt SUPERCHROME (Moca Approved), platte cm.39,5x45 • **FR** Plaque électriques lisse chromée SUPERCHROME (Moca Approved), plaque cm.39,5x45 • **ES FRY-TOP ELÉCTRICO LISO CROMADO SUPERCHROME (MOCA APPROVED), PLANCHA CM.39,5X45**  
**cm. 40x 60x 28h**

⚡ 4,5 kW  
400V~3N  
230V~3  
50/60 Hz

**1.945,00**  
49 / 0,19

**FTLT-64ETSS**  
16060430

Fry-top elettrico liscio CROMO LUCIDO, piastra cm.39,5x45  
**EN** Electric Fry-top smooth POLISHED CHROME, plate cm.39,5x45 • **DE** Griddleplatte elektrische glatt POLIERTEM CHROM, platte cm.39,5x45 • **FR** Plaque électriques lisse CHROME POLI, plaque cm.39,5x45 • **ES FRY-TOP ELÉCTRICO LISO CROMO PULIDO, PLANCHA CM.39,5X45**  
**cm. 40x 60x 28h**

⚡ 4,5 kW  
400V~3N  
230V~3  
50/60 Hz

**1.945,00**  
49 / 0,19



Le immagini presentate non sono vincolanti. La ditta si riserva di apportare modifiche senza preavviso. • The pictures are purely representative. The manufacturer reserves the right to modify the technical data and models without previous notice. • Les images



présentées ne nous engagent pas. La Société se réserve le droit d'apporter tout modification sans préavis. • Die dargestellten Abbildungen sind nicht verbindlich. Technische Änderungen vorbehalten. • Las imágenes presentadas no son vinculantes. El Fabricante se reserva el derecho de modificar sus productos sin previo aviso.

03/23

**35**

60

# FRY-TOP ELETTRICI - TOP

MOD. \_\_\_\_\_  
COD. \_\_\_\_\_

DESCRIZIONE/DESCRIPTION/BEZEICHNUNG/DESCRIPTION/DESCRIPCIÓN  
DIMENSIONI/DIMENSIONS/ABMESSUNGEN/DIMENSIONS/DIMENSIONES

POTENZA/POWER/LEISTUNG/PUISSANCE/POTENCIA  
VOLTAGGIO/VOLTAGE/SPANNUNG/VOLTAGE/VOLTAJE

⚡ kW  
kcal/h

⚡ kw  
V~  
Hz

PREZZO/PRICE €  
PREIS/PRIX/PRECIO €  
KG / M<sup>3</sup>

**FTRT-64ET**  
16060433

Fry-top elettrico rigato, piastra cm.39,5x45  
**EN** Electric Fry-top grooved griddle, plate cm.39,5x45 • **DE** Griddleplatte elektrische gerillt, platte cm.39,5x45 • **FR** Plaque électriques nervurée, plaque cm.39,5x45 • **ES FRY-TOP ELÉCTRICO ESTRIADO, PLANCHA CM.39,5X45**  
**cm. 40x 60x 28h**

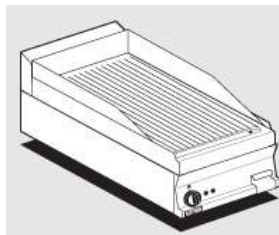

⚡ 4,5 kW **1.628,00**  
400V~3N 49 / 0,19  
230V~3  
50/60 Hz



**FTRT-64ETS**  
16060436

Fry-top elettrico rigato cromato SUPERCHROME (Moca Approved), piastra cm.39,5x45  
**EN** Electric Fry-top grooved chromed griddle SUPERCHROME (Moca Approved), plate cm.39,5x45 • **DE** Griddleplatte elektrische gerillt hartverchromt SUPERCHROME (Moca Approved), platte cm.39,5x45 • **FR** Plaque électriques nervurée chromée SUPERCHROME (Moca Approved), plaque cm.39,5x45 • **ES FRY-TOP ELÉCTRICO ESTRIADO CROMADO SUPERCHROME (MOCA APPROVED), PLANCHA CM.39,5X45**  
**cm. 40x 60x 28h**

⚡ 4,5 kW **2.132,00**  
400V~3N 49 / 0,19  
230V~3  
50/60 Hz



**FTLT-66ET**  
16060631

Fry-top elettrico liscio, piastra cm.59,5x45 - 2 zone di cottura  
**EN** Electric Fry-top smooth griddle, plate cm.59,5x45 - 2 cooking areas • **DE** Griddleplatte elektrische glatt, platte cm.59,5x45 - 2 Heizzonen • **FR** Plaque électriques lisse, plaque cm.59,5x45 - 2 zones de cuisson • **ES FRY-TOP ELÉCTRICO LISO, PLANCHA CM.59,5X45 - 2 ZONAS DE COCCIÓN**  
**cm. 60x 60x 28h**



⚡ 6,75 kW **1.860,00**  
400V~3N 66 / 0,28  
230V~3  
50/60 Hz



**FTLT-66ETS**  
16060634

Fry-top elettrico liscio cromato SUPERCHROME (Moca Approved), piastra cm.59,5x45 - 2 zone di cottura  
**EN** Electric Fry-top smooth chromed griddle SUPERCHROME (Moca Approved), plate cm.59,5x45 - 2 cooking areas • **DE** Griddleplatte elektrische glatt hartverchromt SUPERCHROME (Moca Approved), platte cm.59,5x45 - 2 Heizzonen • **FR** Plaque électriques lisse chromée SUPERCHROME (Moca Approved), plaque cm.59,5x45 - 2 zones de cuisson • **ES FRY-TOP ELÉCTRICO LISO CROMADO SUPERCHROME (MOCA APPROVED), PLANCHA CM.59,5X45 - 2 ZONAS DE COCCIÓN**  
**cm. 60x 60x 28h**

⚡ 6,75 kW **2.516,00**  
400V~3N 66 / 0,28  
230V~3  
50/60 Hz



**FTLT-66ETSS**  
16060630

Fry-top elettrico liscio CROMO LUCIDO, piastra cm.59,5x45 - 2 zone di cottura  
**EN** Electric Fry-top smooth POLISHED CHROME, plate cm.59,5x45 - 2 cooking areas • **DE** Griddleplatte elektrische glatt POLIERTEM CHROM, platte cm.59,5x45 - 2 Heizzonen • **FR** Plaque électriques lisse CHROME POLI, plaque cm.59,5x45 - 2 zones de cuisson • **ES FRY-TOP ELÉCTRICO LISO CROMO PULIDO, PLANCHA CM.59,5X45 - 2 ZONAS DE COCCIÓN**  
**cm. 60x 60x 28h**

⚡ 6,75 kW **2.516,00**  
400V~3N 66 / 0,28  
230V~3  
50/60 Hz



# FRY-TOP ELETTRICI - TOP

MOD. \_\_\_\_\_  
COD. \_\_\_\_\_

DESCRIZIONE/DESCRIPTION/BEZEICHNUNG/DESCRIPTION/DESCRIPCIÓN  
DIMENSIONI/DIMENSIONS/ABMESSUNGEN/DIMENSIONS/DIMENSIONES

POTENZA/POWER/LEISTUNG/PUISSANCE/POTENCIA  
VOLTAGGIO/VOLTAGE/SPANNUNG/VOLTAGE/VOLTAJE

⚡ kW kcal/h  
⚡ kW V~ Hz

PREZZO/PRICE €  
PREIS/PRIX/PRECIO €  
KG / M<sup>3</sup>

**FTLRT-66ET** Fry-top elettrico 1/2 rigato + 1/2 liscio, piastra cm.59,5x45 - 2 zone di cottura  
16060632  
**EN** Electric Fry-top 1/2 grooved + 1/2 smooth, plate cm.59,5x45 - 2 cooking areas • **DE** Griddleplatte elektrische 1/2 gerillt + 1/2 glatt, platte cm.59,5x45 - 2 Heizzonen • **FR** Plaque électriques 1/2 nervurée + 1/2 lisse, plaque cm.59,5x45 - 2 zones de cuisson • **ES FRY-TOP ELÉCTRICO 1/2 ESTRIADO + 1/2 LISO, PLANCHA CM.59,5X45 - 2 ZONAS DE COCCIÓN**  
cm. 60x 60x 28h

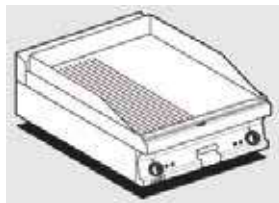

⚡ 6,75 kW 2.025,00  
400V~3N 66 / 0,28  
230V~3  
50/60 Hz



**FTLRT-66ETS** Fry-top elettrico 1/2 rigato + 1/2 liscio cromato SUPERCHROME (Moca Approved), piastra cm.59,5x45 - 2 zone di cottura  
16060635  
**EN** Electric Fry-top 1/2 grooved + 1/2 smooth chromed griddle SUPERCHROME (Moca Approved), plate cm.59,5x45 - 2 cooking areas • **DE** Griddleplatte elektrische 1/2 gerillt + 1/2 glatt hartverchromt SUPERCHROME (Moca Approved), platte cm.59,5x45 - 2 Heizzonen • **FR** Plaque électriques 1/2 nervurée + 1/2 lisse chromée SUPERCHROME (Moca Approved), plaque cm.59,5x45 - 2 zones de cuisson • **ES FRY-TOP ELÉCTRICO 1/2 ESTRIADO + 1/2 LISO CROMADO SUPERCHROME (MOCA APPROVED), PLANCHA CM.59,5X45 - 2 ZONAS DE COCCIÓN**  
cm. 60x 60x 28h

⚡ 6,75 kW 2.690,00  
400V~3N 66 / 0,28  
230V~3  
50/60 Hz



**FTRT-66ET** Fry-top elettrico rigato, piastra cm.59,5x45 - 2 zone di cottura  
16060633  
**EN** Electric Fry-top grooved griddle, plate cm.59,5x45 - 2 cooking areas • **DE** Griddleplatte elektrische gerillt, platte cm.59,5x45 - 2 Heizzonen • **FR** Plaque électriques nervurée, plaque cm.59,5x45 - 2 zones de cuisson • **ES FRY-TOP ELÉCTRICO ESTRIADO, PLANCHA CM.59,5X45 - 2 ZONAS DE COCCIÓN**  
cm. 60x 60x 28h



⚡ 6,75 kW 2.214,00  
400V~3N 66 / 0,28  
230V~3  
50/60 Hz



**FTRT-66ETS** Fry-top elettrico rigato cromato SUPERCHROME (Moca Approved), piastra cm.59,5x45 - 2 zone di cottura  
16060636  
**EN** Electric Fry-top grooved chromed griddle SUPERCHROME (Moca Approved), plate cm.59,5x45 - 2 cooking areas • **DE** Griddleplatte elektrische gerillt hartverchromt SUPERCHROME (Moca Approved), platte cm.59,5x45 - 2 Heizzonen • **FR** Plaque électriques nervurée chromée SUPERCHROME (Moca Approved), plaque cm.59,5x45 - 2 zones de cuisson • **ES FRY-TOP ELÉCTRICO ESTRIADO CROMADO SUPERCHROME (MOCA APPROVED), PLANCHA CM.59,5X45 - 2 ZONAS DE COCCIÓN**  
cm. 60x 60x 28h

⚡ 6,75 kW 2.872,00  
400V~3N 66 / 0,28  
230V~3  
50/60 Hz



60

# FRY-TOP ELETTRICI - TOP

MOD. \_\_\_\_\_  
COD. \_\_\_\_\_

DESCRIZIONE/DESCRIPTION/BEZEICHNUNG/DESCRIPTION/DESCRIPCIÓN  
DIMENSIONI/DIMENSIONS/ABMESSUNGEN/DIMENSIONS/DIMENSIONES

POTENZA/POWER/LEISTUNG/PUISSANCE/POTENCIA  
VOLTAGGIO/VOLTAGE/SPANNUNG/VOLTAGE/VOLTAJE

⚡ kW \_\_\_\_\_  
kcal/h \_\_\_\_\_  
V~ \_\_\_\_\_  
Hz \_\_\_\_\_

PREZZO/PRICE € \_\_\_\_\_  
PREIS/PRIX/PRECIO € \_\_\_\_\_  
KG / M<sup>3</sup> \_\_\_\_\_

**FTLT-68ET**  
16060831

Fry-top elettrico liscio, piastra cm.79,5x45 - 2 zone di cottura  
**EN** Electric Fry-top smooth griddle, plate cm.79,5x45 - 2 cooking areas  
• **DE** Griddleplatte elektrische glatt, platte cm.79,5x45 - 2 Heizzonen  
• **FR** Plaque électriques lisse, plaque cm.79,5x45 - 2 zones de cuisson  
• **ES FRY-TOP ELÉCTRICO LISO, PLANCHA CM.79,5X45 - 2 ZONAS DE COCCIÓN**  
**cm. 80x 60x 28h**



⚡ 9 kW \_\_\_\_\_ **2.740,00**  
400V~3N \_\_\_\_\_ 81 / 0,37  
230V~3 \_\_\_\_\_  
50/60 Hz \_\_\_\_\_

**FTLT-68ETS**  
16060834

Fry-top elettrico liscio cromato SUPERCHROME (Moca Approved), piastra cm.79,5x45 - 2 zone di cottura  
**EN** Electric Fry-top smooth chromed griddle SUPERCHROME (Moca Approved), plate cm.79,5x45 - 2 cooking areas • **DE** Griddleplatte elektrische glatt hartverchromt SUPERCHROME (Moca Approved), platte cm.79,5x45 - 2 Heizzonen • **FR** Plaque électriques lisse chromée SUPERCHROME (Moca Approved), plaque cm.79,5x45 - 2 zones de cuisson • **ES FRY-TOP ELÉCTRICO LISO CROMADO SUPERCHROME (MOCA APPROVED), PLANCHA CM.79,5X45 - 2 ZONAS DE COCCIÓN**  
**cm. 80x 60x 28h**



⚡ 9 kW \_\_\_\_\_ **3.360,00**  
400V~3N \_\_\_\_\_ 81 / 0,37  
230V~3 \_\_\_\_\_  
50/60 Hz \_\_\_\_\_

**FTLT-68ETSS**  
16060830

Fry-top elettrico liscio CROMO LUCIDO, piastra cm.79,5x45 - 2 zone di cottura  
**EN** Electric Fry-top smooth POLISHED CHROME, plate cm.79,5x45 - 2 cooking areas • **DE** Griddleplatte elektrische glatt POLIERTEM CHROM, platte cm.79,5x45 - 2 Heizzonen • **FR** Plaque électriques lisse CHROME POLI, plaque cm.79,5x45 - 2 zones de cuisson • **ES FRY-TOP ELÉCTRICO LISO CROMO PULIDO, PLANCHA CM.79,5X45 - 2 ZONAS DE COCCIÓN**  
**cm. 80x 60x 28h**



⚡ 9 kW \_\_\_\_\_ **3.360,00**  
400V~3N \_\_\_\_\_ 81 / 0,37  
230V~3 \_\_\_\_\_  
50/60 Hz \_\_\_\_\_

**FTLRT-68ET**  
16060832

Fry-top elettrico 1/2 rigato + 1/2 liscio, piastra cm.79,5x45 - 2 zone di cottura  
**EN** Electric Fry-top 1/2 grooved + 1/2 smooth, plate cm.79,5x45 - 2 cooking areas • **DE** Griddleplatte elektrische 1/2 gerillt + 1/2 glatt, platte cm.79,5x45 - 2 Heizzonen • **FR** Plaque électriques 1/2 nervurée + 1/2 lisse, plaque cm.79,5x45 - 2 zones de cuisson • **ES FRY-TOP ELÉCTRICO 1/2 ESTRIADO + 1/2 LISO, PLANCHA CM.79,5X45 - 2 ZONAS DE COCCIÓN**  
**cm. 80x 60x 28h**



⚡ 9 kW \_\_\_\_\_ **2.915,00**  
400V~3N \_\_\_\_\_ 81 / 0,37  
230V~3 \_\_\_\_\_  
50/60 Hz \_\_\_\_\_

**FTLRT-68ETS**  
16060835

Fry-top elettrico 1/2 rigato + 1/2 liscio cromato SUPERCHROME (Moca Approved), piastra cm.79,5x45 - 2 zone di cottura  
**EN** Electric Fry-top 1/2 grooved + 1/2 smooth chromed griddle SUPERCHROME (Moca Approved), plate cm.79,5x45 - 2 cooking areas  
• **DE** Griddleplatte elektrische 1/2 gerillt + 1/2 glatt hartverchromt SUPERCHROME (Moca Approved), platte cm.79,5x45 - 2 Heizzonen  
• **FR** Plaque électriques 1/2 nervurée + 1/2 lisse chromée SUPERCHROME (Moca Approved), plaque cm.79,5x45 - 2 zones de cuisson • **ES FRY-TOP ELÉCTRICO 1/2 ESTRIADO + 1/2 LISO CROMADO SUPERCHROME (MOCA APPROVED), PLANCHA CM.79,5X45 - 2 ZONAS DE COCCIÓN**  
**cm. 80x 60x 28h**



⚡ 9 kW \_\_\_\_\_ **3.535,00**  
400V~3N \_\_\_\_\_ 81 / 0,37  
230V~3 \_\_\_\_\_  
50/60 Hz \_\_\_\_\_

# FRY-TOP ELETTRICI - TOP

MOD. \_\_\_\_\_  
COD. \_\_\_\_\_

DESCRIZIONE/DESCRIPTION/BEZEICHNUNG/DESCRIPTION/DESCRIPCIÓN  
DIMENSIONI/DIMENSIONS/ABMESSUNGEN/DIMENSIONS/DIMENSIONES

POTENZA/POWER/LEISTUNG/PUISSANCE/POTENCIA  
VOLTAGGIO/VOLTAGE/SPANNUNG/VOLTAGE/VOLTAJE

⚡ kW  
kcal/h

⚡ kW  
V~  
Hz

PREZZO/PRICE €  
PREIS/PRIX/PRECIO €  
KG / M<sup>3</sup>

**FTRT-68ET**  
16060833

Fry-top elettrico rigato, piastra cm.79,5x45 - 2 zone di cottura  
**EN** Electric Fry-top grooved griddle, plate cm.79,5x45 - 2 cooking areas  
• **DE** Griddleplatte elektrische gerillt, platte cm.79,5x45 - 2 Heizzonen  
• **FR** Plaque électriques nervurée, plaque cm.79,5x45 - 2 zones de cuisson  
• **ES FRY-TOP ELÉCTRICO ESTRIADO, PLANCHA CM.79,5X45 - 2 ZONAS DE COCCIÓN**

cm. 80x 60x 28h



⚡ 9 kW **3.087,00**  
400V~3N 81 / 0,37  
230V~3  
50/60 Hz



**FTRT-68ETS**  
16060836

Fry-top elettrico rigato cromato SUPERCHROME (Moca Approved), piastra cm.79,5x45 - 2 zone di cottura  
**EN** Electric Fry-top grooved chromed griddle SUPERCHROME (Moca Approved), plate cm.79,5x45 - 2 cooking areas • **DE** Griddleplatte elektrische gerillt hartverchromt SUPERCHROME (Moca Approved), platte cm.79,5x45 - 2 Heizzonen • **FR** Plaque électriques nervurée chromée SUPERCHROME (Moca Approved), plaque cm.79,5x45 - 2 zones de cuisson • **ES FRY-TOP ELÉCTRICO ESTRIADO CROMADO SUPERCHROME (MOCA APPROVED), PLANCHA CM.79,5X45 - 2 ZONAS DE COCCIÓN**

cm. 80x 60x 28h

⚡ 9 kW **3.712,00**  
400V~3N 81 / 0,37  
230V~3  
50/60 Hz



**FTLT-610ET**  
16061031

Fry-top elettrico liscio, piastra cm.99,5x45 - 2 zone di cottura  
**EN** Electric Fry-top smooth griddle, plate cm.99,5x45 - 2 cooking areas  
• **DE** Griddleplatte elektrische glatt, platte cm.99,5x45 - 2 Heizzonen  
• **FR** Plaque électriques lisse, plaque cm.99,5x45 - 2 zones de cuisson  
• **ES FRY-TOP ELÉCTRICO LISO, PLANCHA CM.99,5X45 - 2 ZONAS DE COCCIÓN**

cm. 100x 60x 28h



⚡ 11,25 kW **3.118,00**  
400V~3N 88 / 0,46  
50/60 Hz

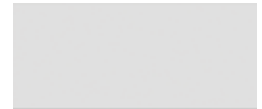

**FTLT-610ETS**  
16061034

Fry-top elettrico liscio cromato SUPERCHROME (Moca Approved), piastra cm.99,5x45 - 2 zone di cottura  
**EN** Electric Fry-top smooth chromed griddle SUPERCHROME (Moca Approved), plate cm.99,5x45 - 2 cooking areas • **DE** Griddleplatte elektrische glatt hartverchromt SUPERCHROME (Moca Approved), platte cm.99,5x45 - 2 Heizzonen • **FR** Plaque électriques lisse chromée SUPERCHROME (Moca Approved), plaque cm.99,5x45 - 2 zones de cuisson • **ES FRY-TOP ELÉCTRICO LISO CROMADO SUPERCHROME (MOCA APPROVED), PLANCHA CM.99,5X45 - 2 ZONAS DE COCCIÓN**

cm. 100x 60x 28h

⚡ 11,25 kW **3.713,00**  
400V~3N 88 / 0,46  
50/60 Hz

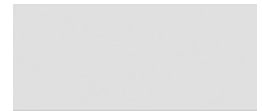

**FTLT-610ETSS**  
16061030

Fry-top elettrico liscio CROMO LUCIDO, piastra cm.99,5x45 - 2 zone di cottura  
**EN** Electric Fry-top smooth POLISHED CHROME, plate cm.99,5x45 - 2 cooking areas • **DE** Griddleplatte elektrische glatt POLIERTEM CHROM, platte cm.99,5x45 - 2 Heizzonen • **FR** Plaque électriques lisse CHROME POLI, plaque cm.99,5x45 - 2 zones de cuisson • **ES FRY-TOP ELÉCTRICO LISO CROMO PULIDO, PLANCHA CM.99,5X45 - 2 ZONAS DE COCCIÓN**

cm. 100x 60x 28h

⚡ 11,25 kW **3.713,00**  
400V~3N 88 / 0,46  
50/60 Hz

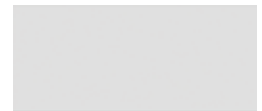

69

# FRY-TOP A GAS - TOP

MOD. \_\_\_\_\_  
COD. \_\_\_\_\_

DESCRIZIONE/DESCRIPTION/BEZEICHNUNG/DESCRIPTION/DESCRIPCIÓN  
DIMENSIONI/DIMENSIONS/ABMESSUNGEN/DIMENSIONS/DIMENSIONES

POTENZA/POWER/LEISTUNG/PUISSANCE/POTENCIA  
VOLTAGGIO/VOLTAGE/SPANNUNG/VOLTAGE/VOLTAJE

⚡ kW kcal/h  
⚡ kw V~ Hz

PREZZO/PRICE €  
PREIS/PRIX/PRECIO €  
KG / M<sup>3</sup>

**FTLRT-610ET** Fry-top elettrico 2/5 rigato + 3/5 liscio, piastra cm.99,5x45 - 2 zone di cottura  
16061032

**EN** Electric Fry-top 2/5 grooved + 3/5 smooth, plate cm.99,5x45 - 2 cooking areas • **DE** Griddleplatte elektrische 2/5 gerillt + 3/5 glatt, platte cm.99,5x45 - 2 Heizzonen • **FR** Plaque électriques 2/5 nervurée + 3/5 lisse, plaque cm.99,5x45 - 2 zones de cuisson • **ES FRY-TOP ELÉCTRICO 2/5 ESTRIADO + 3/5 LISO, PLANCHA CM.99,5X45 - 2 ZONAS DE COCCIÓN**  
**cm. 100x 60x 28h**



⚡ 11,25 kW 3.307,00  
400V~3N 88 / 0,46  
50/60 Hz



**FTLRT-610ETS** Fry-top elettrico 2/5 rigato + 3/5 liscio cromato SUPERCHROME (Moca Approved), piastra cm.99,5x45 - 2 zone di cottura  
16061035

**EN** Electric Fry-top 2/5 grooved + 3/5 smooth chromed griddle SUPERCHROME (Moca Approved), plate cm.99,5x45 - 2 cooking areas • **DE** Griddleplatte elektrische 2/5 gerillt + 3/5 glatt hartverchromt SUPERCHROME (Moca Approved), platte cm.99,5x45 - 2 Heizzonen • **FR** Plaque électriques 2/5 nervurée + 3/5 lisse chromée SUPERCHROME (Moca Approved), plaque cm.99,5x45 - 2 zones de cuisson • **ES FRY-TOP ELÉCTRICO 2/5 ESTRIADO + 3/5 LISO CROMADO SUPERCHROME (MOCA APPROVED), PLANCHA CM.99,5X45 - 2 ZONAS DE COCCIÓN**  
**cm. 100x 60x 28h**

⚡ 11,25 kW 3.888,00  
400V~3N 88 / 0,46  
50/60 Hz



**FTRT-610ET** Fry-top elettrico rigato, piastra cm.99,5x45 - 2 zone di cottura  
16061033

**EN** Electric Fry-top grooved griddle, plate cm.99,5x45 - 2 cooking areas • **DE** Griddleplatte elektrische gerillt, platte cm.99,5x45 - 2 Heizzonen • **FR** Plaque électriques nervurée, plaque cm.99,5x45 - 2 zones de cuisson • **ES FRY-TOP ELÉCTRICO ESTRIADO, PLANCHA CM.99,5X45 - 2 ZONAS DE COCCIÓN**  
**cm. 100x 60x 28h**



⚡ 11,25 kW 3.494,00  
400V~3N 88 / 0,46  
50/60 Hz



**FTRT-610ETS** Fry-top elettrico rigato cromato SUPERCHROME (Moca Approved), piastra cm.99,5x45 - 2 zone di cottura  
16061036

**EN** Electric Fry-top grooved chromed griddle SUPERCHROME (Moca Approved), plate cm.99,5x45 - 2 cooking areas • **DE** Griddleplatte elektrische gerillt hartverchromt SUPERCHROME (Moca Approved), platte cm.99,5x45 - 2 Heizzonen • **FR** Plaque électriques nervurée chromée SUPERCHROME (Moca Approved), plaque cm.99,5x45 - 2 zones de cuisson • **ES FRY-TOP ELÉCTRICO ESTRIADO CROMADO SUPERCHROME (MOCA APPROVED), PLANCHA CM.99,5X45 - 2 ZONAS DE COCCIÓN**  
**cm. 100x 60x 28h**

⚡ 11,25 kW 4.080,00  
400V~3N 88 / 0,46  
50/60 Hz



**FTLT-64G** Fry-top gas liscio, piastra cm.39,5x45  
16230451  
**EN** Gas Fry-top smooth griddle, plate cm.39,5x45 • **DE** Gas-griddleplatte glatt, platte cm.39,5x45 • **FR** Plaque gaz lisse, plaque cm.39,5x45 • **ES FRY-TOP GAS LISO, PLANCHA CM.39,5X45**  
**cm. 40x 60x 28h**



⚡ 6 kW 1.496,00  
5.160 kcal/h 47 / 0,19



**FTLT-64GS** Fry-top gas liscio cromato SUPERCHROME (Moca Approved), piastra cm.39,5x45  
16230454  
**EN** Gas Fry-top smooth chromed griddle SUPERCHROME (Moca Approved), plate cm.39,5x45 • **DE** Gas-griddleplatte glatt hartverchromt SUPERCHROME (Moca Approved), platte cm.39,5x45 • **FR** Plaque gaz lisse chromée SUPERCHROME (Moca Approved), plaque cm.39,5x45 • **ES FRY-TOP GAS LISO CROMADO SUPERCHROME (MOCA APPROVED), PLANCHA CM.39,5X45**  
**cm. 40x 60x 28h**

⚡ 6 kW 1.986,00  
5.160 kcal/h 47 / 0,19



**FTLT-64GSS** Fry-top gas liscio CROMO LUCIDO, piastra cm.39,5x45  
16230450  
**EN** Gas Fry-top smooth POLISHED CHROME, plate cm.39,5x45 • **DE** Gas-griddleplatte glatt POLIERTEM CHROM, platte cm.39,5x45 • **FR** Plaque gaz lisse CHROME POLI, plaque cm.39,5x45 • **ES FRY-TOP GAS LISO CROMO PULIDO, PLANCHA CM.39,5X45**  
**cm. 40x 60x 28h**

⚡ 6 kW 1.986,00  
5.160 kcal/h 47 / 0,19



03/23  
40

Le immagini presentate non sono vincolanti. La ditta si riserva di apportare modifiche senza preavviso. • The pictures are purely representative. The manufacturer reserves the right to modify the technical data and models without previous notice. • Les images présentées ne nous engagent pas. La Société se réserve le



droit d'apporter tout modification sans préavis. • Die dargestellten Abbildungen sind nicht verbindlich. Technische Änderungen vorbehalten. • Las imágenes presentadas no son vinculantes. El Fabricante se reserva el derecho de modificar sus productos sin previo aviso.



# FRY-TOP A GAS - TOP

MOD. \_\_\_\_\_  
COD.

DESCRIZIONE/DESCRIPTION/BEZEICHNUNG/DESCRIPTION/DESCRIPCIÓN  
DIMENSIONI/DIMENSIONS/ABMESSUNGEN/DIMENSIONS/DIMENSIONES

POTENZA/POWER/LEISTUNG/PUISSANCE/POTENCIA  
VOLTAGGIO/VOLTAGE/SPANNUNG/VOLTAGE/VOLTAJE

6 kW  
5.160 kcal/h

PREZZO/PRICE €  
KG / M<sup>3</sup>

**FTRT-64G**  
16230453

Fry-top gas rigato, piastra cm.39,5x45  
**EN** Gas Fry-top grooved griddle, plate cm.39,5x45 • **DE** Gas-griddleplatte gerillt, platte cm.39,5x45 • **FR** Plaque gaz nervurée, plaque cm.39,5x45 • **ES FRY-TOP GAS ESTRIADO, PLANCHA CM.39,5X45**  
cm. 40x 60x 28h

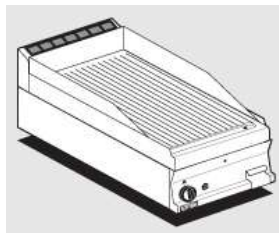

6 kW  
5.160 kcal/h

**1.635,00**  
47 / 0,19

**FTRT-64GS**  
16230456

Fry-top gas rigato cromato SUPERCHROME (Moca Approved), piastra cm.39,5x45  
**EN** Gas Fry-top grooved chromed griddle SUPERCHROME (Moca Approved), plate cm.39,5x45 • **DE** Gas-griddleplatte gerillt hartverchromt SUPERCHROME (Moca Approved), platte cm.39,5x45 • **FR** Plaque gaz nervurée chromée SUPERCHROME (Moca Approved), plaque cm.39,5x45 • **ES FRY-TOP GAS ESTRIADO CROMADO SUPERCHROME (MOCA APPROVED), PLANCHA CM.39,5X45**  
cm. 40x 60x 28h

6 kW  
5.160 kcal/h

**2.190,00**  
47 / 0,19

**FTLT-66G**  
16230651

Fry-top gas liscio, piastra cm.59,5x45 - 2 zone di cottura  
**EN** Gas Fry-top smooth griddle, plate cm.59,5x45 - 2 cooking areas • **DE** Gas-griddleplatte glatt, platte cm.59,5x45 - 2 Heizzonen • **FR** Plaque gaz lisse, plaque cm.59,5x45 - 2 zones de cuisson • **ES FRY-TOP GAS LISO, PLANCHA CM.59,5X45 - 2 ZONAS DE COCCIÓN**  
cm. 60x 60x 28h

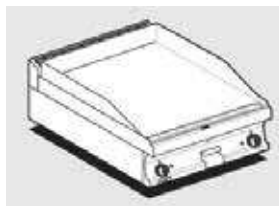

9 kW  
7.740 kcal/h

**2.131,00**  
65 / 0,28

**FTLT-66GS**  
16230654

Fry-top gas liscio cromato SUPERCHROME (Moca Approved), piastra cm.59,5x45 - 2 zone di cottura  
**EN** Gas Fry-top smooth chromed griddle SUPERCHROME (Moca Approved), plate cm.59,5x45 - 2 cooking areas • **DE** Gas-griddleplatte glatt hartverchromt SUPERCHROME (Moca Approved), platte cm.59,5x45 - 2 Heizzonen • **FR** Plaque gaz lisse chromée SUPERCHROME (Moca Approved), plaque cm.59,5x45 - 2 zones de cuisson • **ES FRY-TOP GAS LISO CROMADO SUPERCHROME (MOCA APPROVED), PLANCHA CM.59,5X45 - 2 ZONAS DE COCCIÓN**  
cm. 60x 60x 28h

9 kW  
7.740 kcal/h

**2.565,00**  
65 / 0,28

**FTLT-66GS**  
16230650

Fry-top gas liscio CROMO LUCIDO, piastra cm.59,5x45 - 2 zone di cottura  
**EN** Gas Fry-top smooth POLISHED CHROME, plate cm.59,5x45 - 2 cooking areas • **DE** Gas-griddleplatte glatt POLIERTEM CHROM, platte cm.59,5x45 - 2 Heizzonen • **FR** Plaque gaz lisse CHROME POLI, plaque cm.59,5x45 - 2 zones de cuisson • **ES FRY-TOP GAS LISO CROMO PULIDO, PLANCHA CM.59,5X45 - 2 ZONAS DE COCCIÓN**  
cm. 60x 60x 28h

9 kW  
7.740 kcal/h

**2.565,00**  
65 / 0,28

**FTLRT-66G**  
16230652

Fry-top gas 1/2 rigato + 1/2 liscio, piastra cm.59,5x45 - 2 zone di cottura  
**EN** Gas Fry-top 1/2 grooved + 1/2 smooth, plate cm.59,5x45 - 2 cooking areas • **DE** Gas-griddleplatte 1/2 gerillt + 1/2 glatt, platte cm.59,5x45 - 2 Heizzonen • **FR** Plaque gaz 1/2 nervurée + 1/2 lisse, plaque cm.59,5x45 - 2 zones de cuisson • **ES FRY-TOP GAS 1/2 ESTRIADO + 1/2 LISO, PLANCHA CM.59,5X45 - 2 ZONAS DE COCCIÓN**  
cm. 60x 60x 28h



9 kW  
7.740 kcal/h

**2.290,00**  
65 / 0,28

**FTLRT-66GS**  
16230655

Fry-top gas 1/2 rigato + 1/2 liscio cromato SUPERCHROME (Moca Approved), piastra cm.59,5x45 - 2 zone di cottura  
**EN** Gas Fry-top 1/2 grooved + 1/2 smooth chromed griddle SUPERCHROME (Moca Approved), plate cm.59,5x45 - 2 cooking areas • **DE** Gas-griddleplatte 1/2 gerillt + 1/2 glatt hartverchromt SUPERCHROME (Moca Approved), platte cm.59,5x45 - 2 Heizzonen • **FR** Plaque gaz 1/2 nervurée + 1/2 lisse chromée SUPERCHROME (Moca Approved), plaque cm.59,5x45 - 2 zones de cuisson • **ES FRY-TOP GAS 1/2 ESTRIADO + 1/2 LISO CROMADO SUPERCHROME (MOCA APPROVED), PLANCHA CM.59,5X45 - 2 ZONAS DE COCCIÓN**  
cm. 60x 60x 28h

9 kW  
7.740 kcal/h

**2.625,00**  
65 / 0,28



Le immagini presentate non sono vincolanti. La ditta si riserva di apportare modifiche senza preavviso. • The pictures are purely representative. The manufacturer reserves the right to modify the technical data and models without previous notice. • Les images



présentées ne nous engagent pas. La Société se réserve le droit d'apporter tout modification sans préavis. • Die dargestellten Abbildungen sind nicht verbindlich. Technische Änderungen vorbehalten. • Las imágenes presentadas no son vinculantes. El Fabricante se reserva el derecho de modificar sus productos sin previo aviso.

03/23

41

# FRY-TOP A GAS - TOP

MOD. \_\_\_\_\_  
COD. \_\_\_\_\_

DESCRIZIONE/DESCRIPTION/BEZEICHNUNG/DESCRIPTION/DESCRIPCIÓN  
DIMENSIONI/DIMENSIONS/ABMESSUNGEN/DIMENSIONS/DIMENSIONES

POTENZA/POWER/LEISTUNG/PUISSANCE/POTENCIA  
VOLTAGGIO/VOLTAGE/SPANNUNG/VOLTAGE/VOLTAJE

9 kW  
7.740 kcal/h

PREZZO/PRICE €  
PREIS/PRIX/PRECIO €  
KG / M<sup>3</sup>

**FTRT-66G**  
16230653

Fry-top gas rigato, piastra cm.59,5x45 - 2 zone di cottura  
**EN** Gas Fry-top grooved griddle, plate cm.59,5x45 - 2 cooking areas  
• **DE** Gas-griddleplatte gerillt, platte cm.59,5x45 - 2 Heizzonen • **FR** Plaque gaz nervurée, plaque cm.59,5x45 - 2 zones de cuisson • **ES FRY-TOP GAS ESTRIADO, PLANCHA CM.59,5X45 - 2 ZONAS DE COCCIÓN**  
cm. 60x 60x 28h



9 kW  
7.740 kcal/h

**2.449,00**  
65 / 0,28

**FTRT-66GS**  
16230656

Fry-top gas rigato cromato SUPERCHROME (Moca Approved), piastra cm.59,5x45 - 2 zone di cottura  
**EN** Gas Fry-top grooved chromed griddle SUPERCHROME (Moca Approved), plate cm.59,5x45 - 2 cooking areas • **DE** Gas-griddleplatte gerillt hartverchromt SUPERCHROME (Moca Approved), platte cm.59,5x45 - 2 Heizzonen • **FR** Plaque gaz nervurée chromée SUPERCHROME (Moca Approved), plaque cm.59,5x45 - 2 zones de cuisson • **ES FRY-TOP GAS ESTRIADO CROMADO SUPERCHROME (MOCA APPROVED), PLANCHA CM.59,5X45 - 2 ZONAS DE COCCIÓN**  
cm. 60x 60x 28h

9 kW  
7.740 kcal/h

**2.753,00**  
65 / 0,28

**FTLT-68G**  
16230851

Fry-top gas liscio, piastra cm.79,5x45 - 2 zone di cottura  
**EN** Gas Fry-top smooth griddle, plate cm.79,5x45 - 2 cooking areas  
• **DE** Gas-griddleplatte glatt, platte cm.79,5x45 - 2 Heizzonen • **FR** Plaque gaz lisse, plaque cm.79,5x45 - 2 zones de cuisson • **ES FRY-TOP GAS LISO, PLANCHA CM.79,5X45 - 2 ZONAS DE COCCIÓN**  
cm. 80x 60x 28h

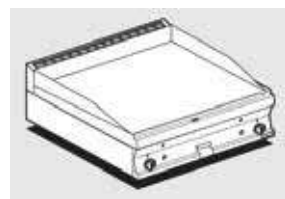

12 kW  
10.320 kcal/h

**2.946,00**  
83 / 0,37

**FTLT-68GS**  
16230854

Fry-top gas liscio cromato SUPERCHROME (Moca Approved), piastra cm.79,5x45 - 2 zone di cottura  
**EN** Gas Fry-top smooth chromed griddle SUPERCHROME (Moca Approved), plate cm.79,5x45 - 2 cooking areas • **DE** Gas-griddleplatte glatt hartverchromt SUPERCHROME (Moca Approved), platte cm.79,5x45 - 2 Heizzonen • **FR** Plaque gaz lisse chromée SUPERCHROME (Moca Approved), plaque cm.79,5x45 - 2 zones de cuisson • **ES FRY-TOP GAS LISO CROMADO SUPERCHROME (MOCA APPROVED), PLANCHA CM.79,5X45 - 2 ZONAS DE COCCIÓN**  
cm. 80x 60x 28h

12 kW  
10.320 kcal/h

**3.502,00**  
83 / 0,37

**FTLT-68GSS**  
16230850

Fry-top gas liscio CROMO LUCIDO, piastra cm.79,5x45 - 2 zone di cottura  
**EN** Gas Fry-top smooth POLISHED CHROME, plate cm.79,5x45 - 2 cooking areas • **DE** Gas-griddleplatte glatt POLIERTEM CHROM, platte cm.79,5x45 - 2 Heizzonen • **FR** Plaque gaz lisse CHROME POLI, plaque cm.79,5x45 - 2 zones de cuisson • **ES FRY-TOP GAS LISO CROMO PULIDO, PLANCHA CM.79,5X45 - 2 ZONAS DE COCCIÓN**  
cm. 80x 60x 28h

12 kW  
10.320 kcal/h

**3.502,00**  
83 / 0,37

**FTLRT-68G**  
16230852

Fry-top gas 1/2 rigato + 1/2 liscio, piastra cm.79,5x45 - 2 zone di cottura  
**EN** Gas Fry-top 1/2 grooved + 1/2 smooth, plate cm.79,5x45 - 2 cooking areas • **DE** Gas-griddleplatte 1/2 gerillt + 1/2 glatt, platte cm.79,5x45 - 2 Heizzonen • **FR** Plaque gaz 1/2 nervurée + 1/2 lisse, plaque cm.79,5x45 - 2 zones de cuisson • **ES FRY-TOP GAS 1/2 ESTRIADO + 1/2 LISO, PLANCHA CM.79,5X45 - 2 ZONAS DE COCCIÓN**  
cm. 80x 60x 28h



12 kW  
10.320 kcal/h

**3.053,00**  
83 / 0,37

**FTLRT-68GS**  
16230855

Fry-top gas 1/2 rigato + 1/2 liscio cromato SUPERCHROME (Moca Approved), piastra cm.79,5x45 - 2 zone di cottura  
**EN** Gas Fry-top 1/2 grooved + 1/2 smooth chromed griddle SUPERCHROME (Moca Approved), plate cm.79,5x45 - 2 cooking areas • **DE** Gas-griddleplatte 1/2 gerillt + 1/2 glatt hartverchromt SUPERCHROME (Moca Approved), platte cm.79,5x45 - 2 Heizzonen • **FR** Plaque gaz 1/2 nervurée + 1/2 lisse chromée SUPERCHROME (Moca Approved), plaque cm.79,5x45 - 2 zones de cuisson • **ES FRY-TOP GAS 1/2 ESTRIADO + 1/2 LISO CROMADO SUPERCHROME (MOCA APPROVED), PLANCHA CM.79,5X45 - 2 ZONAS DE COCCIÓN**  
cm. 80x 60x 28h

12 kW  
10.320 kcal/h

**3.587,00**  
83 / 0,37



# FRY-TOP A GAS - TOP

MOD. \_\_\_\_\_  
COD. \_\_\_\_\_

DESCRIZIONE/DESCRIPTION/BEZEICHNUNG/DESCRIPTION/DESCRIPCIÓN  
DIMENSIONI/DIMENSIONS/ABMESSUNGEN/DIMENSIONS/DIMENSIONES

POTENZA/POWER/LEISTUNG/PUISSANCE/POTENCIA  
VOLTAGGIO/VOLTAGE/SPANNUNG/VOLTAGE/VOLTAJE

⚡ kW  
kcal/h

⚡ kw  
V~  
Hz

PREZZO/PRICE €  
PREIS/PRIX/PRECIO €  
KG / M<sup>3</sup>

**FTRT-68G**  
16230853

Fry-top gas rigato, piastra cm.79,5x45 - 2 zone di cottura  
**EN** Gas Fry-top grooved griddle, plate cm.79,5x45 - 2 cooking areas  
• **DE** Gas-griddleplatte gerillt, platte cm.79,5x45 - 2 Heizzonen • **FR** Plaque gaz nervurée, plaque cm.79,5x45 - 2 zones de cuisson • **ES FRY-TOP GAS ESTRIADO, PLANCHA CM.79,5X45 - 2 ZONAS DE COCCIÓN**  
**cm. 80x 60x 28h**

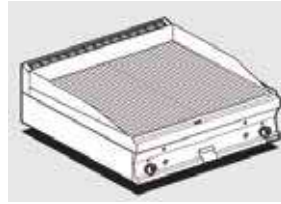

⚡ 12 kW  
10.320 kcal/h

**3.248,00**  
83 / 0,37

**FTRT-68GS**  
16230856

Fry-top gas rigato cromato SUPERCHROME (Moca Approved), piastra cm.79,5x45 - 2 zone di cottura  
**EN** Gas Fry-top grooved chromed griddle SUPERCHROME (Moca Approved), plate cm.79,5x45 - 2 cooking areas • **DE** Gas-griddleplatte gerillt hartverchromt SUPERCHROME (Moca Approved), platte cm.79,5x45 - 2 Heizzonen • **FR** Plaque gaz nervurée chromée SUPERCHROME (Moca Approved), plaque cm.79,5x45 - 2 zones de cuisson • **ES FRY-TOP GAS ESTRIADO CROMADO SUPERCHROME (MOCA APPROVED), PLANCHA CM.79,5X45 - 2 ZONAS DE COCCIÓN**  
**cm. 80x 60x 28h**

⚡ 12 kW  
10.320 kcal/h

**3.779,00**  
83 / 0,37

**FTLT-610G**  
16231051

Fry-top gas liscio, piastra cm.99,5x45 - 2 zone di cottura  
**EN** Gas Fry-top smooth griddle, plate cm.99,5x45 - 2 cooking areas  
• **DE** Gas-griddleplatte glatt, platte cm.99,5x45 - 2 Heizzonen • **FR** Plaque gaz lisse, plaque cm.99,5x45 - 2 zones de cuisson • **ES FRY-TOP GAS LISO, PLANCHA CM.99,5X45 - 2 ZONAS DE COCCIÓN**  
**cm. 100x 60x 28h**



⚡ 15 kW  
12.900 kcal/h

**3.372,00**  
89 / 0,46

**FTLT-610GS**  
16231054

Fry-top gas liscio cromato SUPERCHROME (Moca Approved), piastra cm.99,5x45 - 2 zone di cottura  
**EN** Gas Fry-top smooth chromed griddle SUPERCHROME (Moca Approved), plate cm.99,5x45 - 2 cooking areas • **DE** Gas-griddleplatte glatt hartverchromt SUPERCHROME (Moca Approved), platte cm.99,5x45 - 2 Heizzonen • **FR** Plaque gaz lisse chromée SUPERCHROME (Moca Approved), plaque cm.99,5x45 - 2 zones de cuisson • **ES FRY-TOP GAS LISO CROMADO SUPERCHROME (MOCA APPROVED), PLANCHA CM.99,5X45 - 2 ZONAS DE COCCIÓN**  
**cm. 100x 60x 28h**

⚡ 15 kW  
12.900 kcal/h

**3.931,00**  
89 / 0,46

**FTLT-610GSS**  
16231050

Fry-top gas liscio CROMO LUCIDO, piastra cm.99,5x45 - 2 zone di cottura  
**EN** Gas Fry-top smooth POLISHED CHROME, plate cm.99,5x45 - 2 cooking areas • **DE** Gas-griddleplatte glatt POLIERTEM CHROM, platte cm.99,5x45 - 2 Heizzonen • **FR** Plaque gaz lisse CHROME POLI, plaque cm.99,5x45 - 2 zones de cuisson • **ES FRY-TOP GAS LISO CROMO PULIDO, PLANCHA CM.99,5X45 - 2 ZONAS DE COCCIÓN**  
**cm. 100x 60x 28h**

⚡ 15 kW  
12.900 kcal/h

**3.931,00**  
89 / 0,46

**FTLRT-610G**  
16231052

Fry-top gas 2/5 rigato + 3/5 liscio, piastra cm.99,5x45 - 2 zone di cottura  
**EN** Gas Fry-top 2/5 grooved + 3/5 smooth, plate cm.99,5x45 - 2 cooking areas • **DE** Gas-griddleplatte 2/5 gerillt + 3/5 glatt, platte cm.99,5x45 - 2 Heizzonen • **FR** Plaque gaz 2/5 nervurée + 3/5 lisse, plaque cm.99,5x45 - 2 zones de cuisson • **ES FRY-TOP GAS 2/5 ESTRIADO + 3/5 LISO, PLANCHA CM.99,5X45 - 2 ZONAS DE COCCIÓN**  
**cm. 100x 60x 28h**



⚡ 15 kW  
12.900 kcal/h

**3.554,00**  
89 / 0,46

**FTLRT-610GS**  
16231055

Fry-top gas 2/5 rigato + 3/5 liscio cromato SUPERCHROME (Moca Approved), piastra cm.99,5x45 - 2 zone di cottura  
**EN** Gas Fry-top 2/5 grooved + 3/5 smooth chromed griddle SUPERCHROME (Moca Approved), plate cm.99,5x45 - 2 cooking areas • **DE** Gas-griddleplatte 2/5 gerillt + 3/5 glatt hartverchromt SUPERCHROME (Moca Approved), platte cm.99,5x45 - 2 Heizzonen • **FR** Plaque gaz 2/5 nervurée + 3/5 lisse chromée SUPERCHROME (Moca Approved), plaque cm.99,5x45 - 2 zones de cuisson • **ES FRY-TOP GAS 2/5 ESTRIADO + 3/5 LISO CROMADO SUPERCHROME (MOCA APPROVED), PLANCHA CM.99,5X45 - 2 ZONAS DE COCCIÓN**  
**cm. 100x 60x 28h**

⚡ 15 kW  
12.900 kcal/h

**4.102,00**  
89 / 0,46

# PIANI COTTURA ELETTRICI - TOP

MOD. \_\_\_\_\_  
COD. \_\_\_\_\_

DESCRIZIONE/DESCRIPTION/BEZEICHNUNG/DESCRIPTION/DESCRIPCIÓN  
DIMENSIONI/DIMENSIONS/ABMESSUNGEN/DIMENSIONS/DIMENSIONES

POTENZA/POWER/LEISTUNG/PUISSANCE/POTENCIA  
VOLTAGGIO/VOLTAGE/SPANNUNG/VOLTAGE/VOLTAJE

⚡ kW \_\_\_\_\_  
kcal/h \_\_\_\_\_  
V~ \_\_\_\_\_  
Hz \_\_\_\_\_

PREZZO/PRICE € \_\_\_\_\_  
PREIS/PRIX/PRECIO € \_\_\_\_\_  
KG / M<sup>3</sup> \_\_\_\_\_

**FRT-610G**  
16231053

Fry-top gas rigato, piastra cm.99,5x45 - 2 zone di cottura  
**EN** Gas Fry-top grooved griddle, plate cm.99,5x45 - 2 cooking areas  
• **DE** Gas-griddleplatte gerillt, platte cm.99,5x45 - 2 Heizzonen • **FR**  
Plaque gaz nervurée, plaque cm.99,5x45 - 2 zones de cuisson • **ES**  
**FRY-TOP GAS ESTRIADO, PLANCHA CM.99,5X45 - 2 ZONAS DE COCCIÓN**  
cm. 100x 60x 28h



⚡ 15 kW \_\_\_\_\_ **3.882,00**  
12.900 kcal/h \_\_\_\_\_ 89 / 0,46



**FRT-610GS**  
16231056

Fry-top gas rigato cromato SUPERCHROME (Moca Approved), piastra cm.99,5x45 - 2 zone di cottura  
**EN** Gas Fry-top grooved chromed griddle SUPERCHROME (Moca Approved), plate cm.99,5x45 - 2 cooking areas • **DE** Gas-griddleplatte gerillt hartverchromt SUPERCHROME (Moca Approved), platte cm.99,5x45 - 2 Heizzonen • **FR** Plaque gaz nervurée chromée SUPERCHROME (Moca Approved), plaque cm.99,5x45 - 2 zones de cuisson • **ES**  
**FRY-TOP GAS ESTRIADO CROMADO SUPERCHROME (MOCA APPROVED), PLANCHA CM.99,5X45 - 2 ZONAS DE COCCIÓN**  
cm. 100x 60x 28h

⚡ 15 kW \_\_\_\_\_ **4.274,00**  
12.900 kcal/h \_\_\_\_\_ 89 / 0,46



**RSFT-63EM**  
16630317

Piastra per sandwich sopra frytop elettrici - Piastra cm. 29x40 (ATTENZIONE: PROFONDITA' MACCHINA +cm.10)  
**EN** Sandwiches plate above electric griddle - plate cm. 29x40 (ATTENTION: DEPTH MACHINE +cm.10) • **DE** Sandwiches Platte über Elektrische Griddle - platte cm. 29x40 (VORSICHT: TIEFE MACHINE +cm.10) • **FR** Plaque pour sandwiches au-dessus électrique fry-top - plaque cm. 29x40 (ATTENTION: PROFONDEUR MACHINE +cm.10) • **ES**  
**PLANCIA PARA SÁNDWICHES SOBRE FRY-TOP ELÉCTRICO - PLANCIA CM. 29X40 (ATENCIÓN: PROFUNDIDAD MÁQUINA +CM.10)**  
cm. 32x 61x 41h



⚡ 2,9 kW \_\_\_\_\_ **1.435,00**  
230V~ \_\_\_\_\_ 20 / 0,21  
50/60 Hz \_\_\_\_\_

**PCT-63ET**  
16030330

PIANO COTTURA TRIFASE N. 2 piastre  
**EN** Boiling unit - N. 2 plates • **DE** Kochplatte - N. 2 Kochplatten  
• **FR** Rechaud - N. 2 plaques • **ES**  
**SOBRE DE COCCIÓN - N. 2 PLANCHAS**  
cm. 30x 60x 28h



⚡ 3 kW \_\_\_\_\_ **865,00**  
400V~2N \_\_\_\_\_ 16 / 0,15  
230V~3 \_\_\_\_\_  
230V~ \_\_\_\_\_  
50/60 Hz \_\_\_\_\_

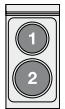

**PCT-66ET**  
16030630

PIANO COTTURA TRIFASE N. 4 piastre  
**EN** Boiling unit - N. 4 plates • **DE** Kochplatte - N. 4 Kochplatten  
• **FR** Rechaud - N. 4 plaques • **ES**  
**SOBRE DE COCCIÓN - N. 4 PLANCHAS**  
cm. 60x 60x 28h



⚡ 6 kW \_\_\_\_\_ **1.392,00**  
400V~3N \_\_\_\_\_ 27 / 0,28  
230V~3 \_\_\_\_\_  
230V~ \_\_\_\_\_  
50/60 Hz \_\_\_\_\_



**PCCT-63ET**  
16030332

PIANO COTTURA VETROCERAMICA TRIFASE - N. 2 zone - vetro cm.25x47  
**EN** Ceramic glass boiling unit - n. 2 zones - glass cm.25x47 • **DE**  
Ceran-Kochplatte dreiphasig - 2 zonen - Glas 25x47 cm • **FR** Plan de cuisson à vitroceramique triphasé N. 2 zones - Verre cm.25x47  
• **ES**  
**SOBRE DE COCCIÓN TRIFÁSICO VITROCERÁMICA - 2 ZONAS - VIDRO CM.35X57**  
cm. 30x 60x 28h



⚡ 3 kW \_\_\_\_\_ **1.929,00**  
400V~2N \_\_\_\_\_ 19 / 0,15  
230V~3 \_\_\_\_\_  
230V~ \_\_\_\_\_  
50/60 Hz \_\_\_\_\_

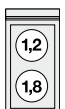

03/23  
**44**

Le immagini presentate non sono vincolanti. La ditta si riserva di apportare modifiche senza preavviso. • The pictures are purely representative. The manufacturer reserves the right to modify the technical data and models without previous notice. • Les images présentées ne nous engagent pas. La Société se réserve le

**LOTUS**

droit d'apporter tout modification sans préavis. • Die dargestellten Abbildungen sind nicht verbindlich. Technische Änderungen vorbehalten. • Las imágenes presentadas no son vinculantes. El Fabricante se reserva el derecho de modificar sus productos sin previo aviso.

**afaq**  
ISO 9001  
Qualità  
SINCE CERTIFICATION



# PIANI COTTURA A INDUZIONE - TOP

MOD. \_\_\_\_\_  
COD. \_\_\_\_\_

DESCRIZIONE/DESCRIPTION/BEZEICHNUNG/DESCRIPTION/DESCRIPCIÓN  
DIMENSIONI/DIMENSIONS/ABMESSUNGEN/DIMENSIONS/DIMENSIONES

POTENZA/POWER/LEISTUNG/PUISSANCE/POTENCIA  
VOLTAGGIO/VOLTAGE/SPANNUNG/VOLTAGE/VOLTAJE

⚡ kW kcal/h  
V~ Hz

PREZZO/PRICE €  
KG / M<sup>3</sup>

**PCCT-66ET**  
16030632

PIANO COTTURA VETROCERAMICA TRIFASE - N. 4 zone - vetro cm.55x47

**EN** Ceramic glass boiling unit - n. 4 zones - glass cm.55x47 • **DE** Ceran-Kochplatte dreiphasig - 4 zonen - Glas 55x47 cm • **FR** Plan de cuisson à vitroceramique triphasé N. 4 zones - Verre cm.55x47  
• **ES SOBRE DE COCCIÓN TRIFÁSICO VITROCERÁMICA - 2 ZONAS - VIDRO CM.35X57**  
cm. 60x 60x 28h



⚡ 6 kW 3.291,00  
400V~3N 26 / 0,28  
230V~3  
230V~  
50/60 Hz

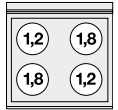

**PCIT-64ET**  
16030433

PIANI COTTURA A INDUZIONE TRIFASE - Vetro cm 35x47 (non posizionare su forni o cassettiere)

**EN** Three-phase induction cooking top - Plates cm 35x47 (do not place on ovens or drawers) • **DE** Induktions-Kochplatte dreiphasig cm 35x47 (nicht Platz auf Öfen oder Schubladen) • **FR** Plan de cuisson à induction triphasé - Verre cm. 35x47 (ne placez pas sur des fours ou des tiroirs) • **ES ENCIMERA INDUCCIÓN TRIFÁSICA - VIDRIO CM. 35X47 (NO COLOQUE EN LOS HORNOS O EN LOS CAJONES)**  
cm. 40x 60x 28h



⚡ 5 kW 5.372,00  
400V~3 23 / 0,19  
50/60 Hz

**PCIWT-64ET**  
16030434

PIANI COTTURA A INDUZIONE WOK 1 piastra induzione - Vetro Ø 30 cm (non posizionare su forni o cassettiere)

**EN** Three-phase wok induction cooking top 1 glass induction plates Ø 30 cm (do not place on ovens or drawers) • **DE** Induktions-Kochplatte dreiphasig Wok 1 Glasinduktionsplatten Ø 30 cm (nicht Platz auf Öfen oder Schubladen) • **FR** Plan de cuisson à induction triphasé wok 1 plaques à induction - Verre Ø 30 cm (ne placez pas sur des fours ou des tiroirs) • **ES ENCIMERA INDUCCIÓN TRIFÁSICA WOK 1 PLACAS INDUCCIÓN - VIDRIO Ø 30 CM (NO COLOQUE EN LOS HORNOS O EN LOS CAJONES)**  
cm. 40x 60x 28h



⚡ 5 kW 5.566,00  
400V~3 23 / 0,19  
50/60 Hz

**PCT-63G**  
16210350

PIANO COTTURA A GAS, 2 FUOCHI

**EN** Gas heated boiling - 2 burners • **DE** Gas-Kochplatte - 2 Kochstellen  
• **FR** Rechaud gaz - 2 feux vifs • **ES SOBRES DE COCCIÓN GAS - 2 QUEMADORES**  
cm. 30x 60x 28h



⚡ 9 kW 1.237,00  
7.740 kcal/h 20 / 0,15

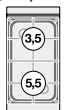

Le immagini presentate non sono vincolanti. La ditta si riserva di apportare modifiche senza preavviso. • The pictures are purely representative. The manufacturer reserves the right to modify the technical data and models without previous notice. • Les images



présentées ne nous engagent pas. La Société se réserve le droit d'apporter tout modification sans préavis. • Die dargestellten Abbildungen sind nicht verbindlich. Technische Änderungen vorbehalten. • Las imágenes presentadas no son vinculantes. El Fabricante se reserva el derecho de modificar sus productos sin previo aviso.

03/23

45

# PIANI COTTURA A GAS - TOP

MOD. \_\_\_\_\_  
COD. \_\_\_\_\_

DESCRIZIONE/DESCRIPTION/BEZEICHNUNG/DESCRIPTION/DESCRIPCIÓN  
DIMENSIONI/DIMENSIONS/ABMESSUNGEN/DIMENSIONS/DIMENSIONES

POTENZA/POWER/LEISTUNG/PUISSANCE/POTENCIA  
VOLTAGGIO/VOLTAGE/SPANNUNG/VOLTAGE/VOLTAJE

⚡ kW  
kcal/h

⚡ kW  
V~  
Hz

PREZZO/PRICE €  
PREIS/PRIX/PRECIO €  
KG / M<sup>3</sup>

**PCT-66G**  
16210650

PIANO COTTURA A GAS, 4 FUOCHI  
**EN** Gas heated boiling - 4 burners • **DE** Gas-Kochplatte - 4 Kochstellen  
• **FR** Rechaud gaz - 4 feux vifs • **ES SOBRES DE COCCIÓN GAS - 4 QUEMADORES**  
cm. 60x 60x 28h



⚡ 18 kW  
15.480 kcal/h

**1.944,00**  
31 / 0,28

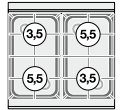

**PCT-610G**  
16211050

PIANO COTTURA A GAS, 6 FUOCHI  
**EN** Gas heated boiling - 6 burners • **DE** Gas-Kochplatte - 6 Kochstellen  
• **FR** Rechaud gaz - 6 feux vifs • **ES SOBRES DE COCCIÓN GAS - 6 QUEMADORES**  
cm. 100x 60x 28h



⚡ 27 kW  
23.220 kcal/h

**3.129,00**  
63 / 0,46

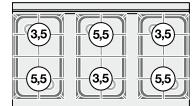

**PC1T-64G**  
16210451

PIANO COTTURA A GAS, 1 FUOCO  
**EN** Gas heated boiling - 1 burner • **DE** Gas-Kochplatte - 1 Kochstellen  
• **FR** Rechaud gaz - 1 feux vifs • **ES SOBRES DE COCCIÓN GAS - 1 QUEMADOR**  
cm. 40x 60x 28h



⚡ 10 kW  
8.600 kcal/h

**1.197,00**  
23 / 0,19



**PC2T-68G**  
16210851

PIANO COTTURA A GAS, 2 FUOCHI  
**EN** Gas heated boiling - 2 burners • **DE** Gas-Kochplatte - 2 Kochstellen  
• **FR** Rechaud gaz - 2 feux vifs • **ES SOBRES DE COCCIÓN GAS - 2 QUEMADORES**  
cm. 80x 60x 28h



⚡ 17 kW  
14.620 kcal/h

**1.889,00**  
39 / 0,37

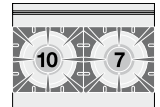

**PC3T-612G**  
16211251

PIANO COTTURA A GAS, 3 FUOCHI  
**EN** Gas heated boiling - 3 burners • **DE** Gas-Kochplatte - 3 Kochstellen  
• **FR** Rechaud gaz - 3 feux vifs • **ES SOBRES DE COCCIÓN GAS - 3 QUEMADORES**  
cm. 120x 60x 28h



⚡ 27 kW  
23.220 kcal/h

**2.764,00**  
54 / 0,55

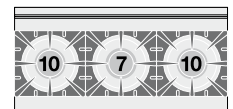

**TPT-64G**  
16290450

TUTTAPIASTRA A GAS Piastra cm 37x50  
**EN** Solid top - Plate cm 37x50 • **DE** Kochplatte - Platte cm 37x50  
• **FR** Toute plaque - Plaque cm 37x50 • **ES PLACA DE COCCIÓN - PLACA CM 37X50**  
cm. 40x 60x 28h



⚡ 5,5 kW  
4.730 kcal/h

**2.050,00**  
54 / 0,19

**TP4T-610G**  
16301050

TUTTA PIASTRA + 4 FUOCHI Piastra cm. 37x50  
**EN** Solid top + 4 burners - Plate 37x50cm • **DE** Kochplatte + 4 Gaskochstellen - Platte 37x50 cm • **FR** Toute plaque + 4 brûleurs - Plaque cm. 37x50 • **ES PLACA DE COCCIÓN + 4 FUEGOS - PLACA CM. 37X50**  
cm. 100x 60x 28h



⚡ 23,5 kW  
20.210 kcal/h

**4.377,00**  
103 / 0,46

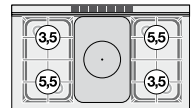

03/23  
**46**

Le immagini presentate non sono vincolanti. La ditta si riserva di apportare modifiche senza preavviso. • The pictures are purely representative. The manufacturer reserves the right to modify the technical data and models without previous notice. • Les images présentées ne nous engagent pas. La Société se réserve le

**LOTUS**

droit d'apporter tout modification sans préavis. • Die dargestellten Abbildungen sind nicht verbindlich. Technische Änderungen vorbehalten. • Las imágenes presentadas no son vincolantes. El Fabricante se reserva el derecho de modificar sus productos sin previo aviso.

**afaq**  
ISO 9001  
Qualità  
SINCE CERTIFICATION



# PIANI LAVORO - TOP

MOD. \_\_\_\_\_  
COD. \_\_\_\_\_

DESCRIZIONE/DESCRIPTION/BEZEICHNUNG/DESCRIPTION/DESCRIPCIÓN  
DIMENSIONI/DIMENSIONS/ABMESSUNGEN/DIMENSIONS/DIMENSIONES

POTENZA/POWER/LEISTUNG/PUISSANCE/POTENCIA  
VOLTAGGIO/VOLTAGE/SPANNUNG/VOLTAGE/VOLTAJE

⚡ kW kcal/h  
⚡ kw V~ Hz

PREZZO/PRICE €  
PREIS/PRIX/PRECIO €  
KG / M<sup>3</sup>

**PLT-62**  
16010200

PIANO DI LAVORO  
**EN** Worktop • **DE** Arbeitsplatte • **FR** Plan de travail • **ES SOBRE DE TRABAJO**  
cm. 20x 60x 28h

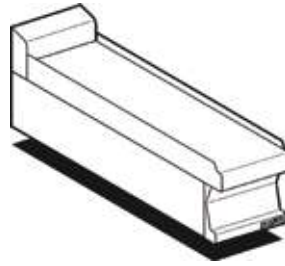

**476,00**  
13 / 0,15

**PLT-63**  
16010300

PIANO DI LAVORO con cassetto inox cm.21x47x15h inox  
**EN** Worktop with inox drawer cm.21x47x15h inox • **DE** Arbeitsplatte mit Schublade inox cm.21x47x15h inox • **FR** Plan de travail avec tiroir inox cm.21x47x15h inox • **ES SOBRE DE TRABAJO CON CAJÓN INOX CM.21X47X15H INOX**  
cm. 30x 60x 28h



**609,00**  
21 / 0,15

**PLT-64**  
16010400

PIANO DI LAVORO con cassetto inox cm.31x47x15h inox  
**EN** Worktop with inox drawer cm.31x47x15h inox • **DE** Arbeitsplatte mit Schublade inox cm.31x47x15h inox • **FR** Plan de travail avec tiroir inox cm.31x47x15h inox • **ES SOBRE DE TRABAJO CON CAJÓN INOX CM.31X47X15H INOX**  
cm. 40x 60x 28h



**642,00**  
22 / 0,19

**PLT-66**  
16010600

PIANO DI LAVORO con cassetto inox cm.51x47x15h inox  
**EN** Worktop with inox drawer cm.51x47x15h inox • **DE** Arbeitsplatte mit Schublade inox cm.51x47x15h inox • **FR** Plan de travail avec tiroir inox cm.51x47x15h inox • **ES SOBRE DE TRABAJO CON CAJÓN INOX CM.51X47X15H INOX**  
cm. 60x 60x 28h



**915,00**  
25 / 0,28

**PLT-68**  
16010800

PIANO DI LAVORO con cassetto inox cm.71x47x15h inox  
**EN** Worktop with inox drawer cm.71x47x15h inox • **DE** Arbeitsplatte mit Schublade inox cm.71x47x15h inox • **FR** Plan de travail avec tiroir inox cm.71x47x15h inox • **ES SOBRE DE TRABAJO CON CAJÓN INOX CM.71X47X15H INOX**  
cm. 80x 60x 28h



**1.120,00**  
38 / 0,37

**PLT-610**  
16011000

PIANO DI LAVORO con 2 cassette inox, 1xcm.51x47x15h + 1xcm.31x47x15h  
**EN** Worktop with 2 inox drawers, 1xcm.51x47x15h + 1xcm.31x47x15h • **DE** Arbeitsplatte mit 2 Schublade inox, 1xcm.51x47x15h + 1xcm.31x47x15h • **FR** Plan de travail avec 2 tiroirs inox, 1xcm.51x47x15h + 1xcm.31x47x15h • **ES SOBRE DE TRABAJO CON 2 CAJONES INOX, 1XCM.51X47X15H + 1XCM.31X47X15H**  
cm. 100x 60x 28h

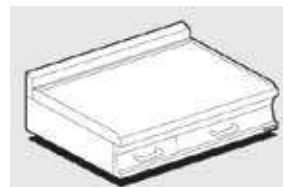

**1.554,00**  
51 / 0,46

**PLA-68**  
06010801

PIANO DI LAVORO AD ANGOLO SU MOBILE  
**EN** Corner base with door • **DE** Eckschrank mit Tür • **FR** Placard d'angle avec porte • **ES BASE ANGULAR CON PUERTA**  
cm.80÷80x 60x 90h



**1.854,00**  
50 / 0,89

60

MOD. \_\_\_\_\_  
COD. \_\_\_\_\_

DESCRIZIONE/DESCRIPTION/BEZEICHNUNG/DESCRIPTION/DESCRIPCIÓN  
DIMENSIONI/DIMENSIONS/ABMESSUNGEN/DIMENSIONS/DIMENSIONES

POTENZA/POWER/LEISTUNG/PUISSANCE/POTENCIA  
VOLTAGGIO/VOLTAGE/SPANNUNG/VOLTAGE/VOLTAJE

⚡ kW kcal/h  
⚡ kw V~ Hz

PREZZO/PRICE €  
PREIS/PRIX/PRECIO €  
KG / M<sup>3</sup>

**LAT-64**  
16020400

LAVELLO 1 VASCA Rubinetto a leva - vasca cm 29x35x14h  
**EN** Sink unit - Lever type tap - Bowl cm 29x35x14h • **DE** Spülbecken  
- Einhebel-Mischbatterie Becken cm 29x35x14h • **FR** Bac-évier avec  
robinetterie - Bac cm 29x35x14h • **ES FREGADERO - GRIFO A  
PALANCA - PILETA CM 29X35X14H**  
cm. 40x 60x 28h



**1.044,00**  
20 / 0,19

**LAT-68**  
16020800

LAVELLO 2 VASCHE cm 29x35x14h Rubinetto a leva  
**EN** Sink unit - Lever type tap - 2 Bowls cm 29x35x14h • **DE** Spülbecken  
- Einhebel-Mischbatterie 2 Becken cm 29x35x14h • **FR** Bac-évier avec  
robinetterie - 2 Bac cm 29x35x14h • **ES FREGADERO - GRIFO A  
PALANCA - 2 PILETA CM 29X35X14H**  
cm. 80x 60x 28h



**1.588,00**  
32 / 0,37

**LAT-610DX**  
16021000

LAVELLO PREDISPOSTO - Vasca cm 29x35x14h Dx Sgocciolatoio cm 60  
Sx - Rubinetto a leva a norme.  
**EN** Sink unit - R/h Bowl cm 29x35x14h - L/h Draining board cm 60  
Suitable for dishwasher - Lever type tap. • **DE** Spülbecken - Becken  
cm 29x35x14h rechts Abtropffläche cm 60 links - Vorbereitung für  
Geschirrspülmaschine - Einhebel-Mischbatterie • **FR** Plan évier - Bac à  
droite cm 29x35x14h Égouttoir à gauche cm 60 Prêdisposé pour lave-  
vaisselle Robinetterie • **ES FREGADERO PREDISPUERTO - PILETA  
CM 29X35X14H DERECHO ESCURRIDOR 60 CM IZQ. -  
GRIFO A PALANCA SEGÚN NORMATIVA**  
cm. 100x 60x 28h



**1.437,00**  
36 / 0,46

**LAT-610SX**  
16021001

LAVELLO PREDISPOSTO - Vasca cm 29x35x14h Sx Sgocciolatoio cm 60  
Dx - Rubinetto a leva a norme.  
**EN** Sink unit - L/h Bowl cm 29x35x14h - R/h Draining board cm 60  
Suitable for dishwasher - Lever type tap. • **DE** Spülbecken - Becken  
cm 29x35x14h links Abtropffläche cm 60 rechts - Vorbereitung für  
Geschirrspülmaschine - Einhebel-Mischbatterie • **FR** Plan évier - Bac à  
gauche cm 29x35x14h Égouttoir à droite cm 60 Prêdisposé pour lave-  
vaisselle Robinetterie • **ES FREGADERO PREDISPUERTO - PILETA  
CM 29X35X14H IZQ. ESCURRIDOR 60 CM DERECHO -  
GRIFO A PALANCA SEGÚN NORMATIVA**  
cm. 100x 60x 28h



**1.437,00**  
36 / 0,46

**LAA-68**  
06020801

LAVELLO AD ANGOLO SU MOBILE Vasca cm 50x40x20h  
**EN** Corner base with sink and door Bowl cm 50x40x20h • **DE**  
Eckschrank mit Spülbecken und mit Tür Becken cm 50x40x20h • **FR**  
Placard d'angle avec porte et évier Cuve cm 50x40x20h • **ES CON  
FREGADERO Y PUERTA CM. CUBA CM 50X40X20H**  
cm.80÷80x 60x 90h



**2.143,00**  
50 / 0,89

**MFM-68EM**  
06490812

BASE CON Forno elettrico multifunzione cm. 46x37x35h, temp:  
50÷250°C, con 1 griglia cm.41x32,5 - porta vetro (non sovrapporre  
elementi ad induzione)  
**EN** Stand with Multifunction electric oven cm. 46x37x35h, temp:  
50÷250°C, with 1 grid cm.41x32,5 - Glass door (no induction top) • **DE**  
unterbau mit Multifunktions-Elektroofen cm. 46x37x35h, temp: 50÷250°C,  
mit 1 Rost cm.41x32,5 - Glastür (nicht Induktions) • **FR** placard avec  
Four électrique à fonctions multiples cm. 46x37x35h, temp: 50÷250°C,  
avec 1 grille cm.41x32,5 - Porte vitrée (il faut pas de induction) • **ES  
MUEBLE CON HORNO ELÉCTRICO MULTIFUNCIONAL  
CM. 46X37X35H, TEMP: 50÷250 °C, CON 1 PARILLA  
CM.41X32,5 - PUERTA VIDRIO (NO INDUCCIÓN)**  
cm. 80x 57,5x 57h



⚡ 3,05 kW  
230V~ 51 / 0,43  
50/60 Hz

# BASE CON FORNO ELETTRICO

MOD. \_\_\_\_\_  
COD. \_\_\_\_\_

DESCRIZIONE/DESCRIPTION/BEZEICHNUNG/DESCRIPTION/DESCRIPCIÓN  
DIMENSIONI/DIMENSIONS/ABMESSUNGEN/DIMENSIONS/DIMENSIONES

POTENZA/POWER/LEISTUNG/PUISSANCE/POTENCIA  
VOLTAGGIO/VOLTAGE/SPANNUNG/VOLTAGE/VOLTAJE

⚡ kW kcal/h  
⚡ kW V~ Hz

PREZZO/PRICE €  
PREIS/PRIX/PRECIO €  
KG / M<sup>3</sup>

**MFM-68EM** BASE CON Forno elettrico multifunzione cm. 46x37x35h, temp: 50÷250°C, con 1 griglia cm.41x32,5 - Porta cieca inox (non sovrapporre elementi ad induzione)  
**EN** Stand with Multifunction electric oven cm. 46x37x35h, temp: 50÷250°C, with 1 grid cm.41x32,5 - Stainless steel door (no induction top) • **DE** unterbau mit Multifunktions-Elektroofen cm. 46x37x35h, temp: 50÷250°C, mit 1 Rost cm.41x32,5 - Edelstahltür (nicht Induktions) • **FR** placard avec Four électrique à fonctions multiples cm. 46x37x35h, temp: 50÷250°C, avec 1 grille cm.41x32,5 - Porte acier inoxydable (il faut pas de induction) • **ES MUEBLE CON HORNO ELÉCTRICO MULTIFUNCIONAL CM. 46X37X35H, TEMP: 50÷250 °C, CON 1 PARILLA CM.41X32,5 - PUERTA CIEGA INOX (NO INDUCCIÓN)**  
**cm. 80x 57,5x 57h**



⚡ 3,05 Kw **2.952,00**  
230V~ 51 / 0,43  
50/60 Hz

**MFM-610EM** BASE CON Forno elettrico multifunzione cm. 64x37x35h, temp: 50÷250°C, con 1 griglia cm.53x32,5 GN1/1 - porta vetro (non sovrapporre elementi ad induzione)  
**EN** Stand with Multifunction electric oven cm. 64x37x35h, temp: 50÷250°C, with 1 grid cm.53x32,5 GN1/1 - Glass door (no induction top) • **DE** unterbau mit Multifunktions-Elektroofen cm. 64x37x35h, temp: 50÷250°C, mit 1 Rost cm.53x32,5 GN1/1 - Glastür (nicht Induktions) • **FR** placard avec Four électrique à fonctions multiples cm. 64x37x35h, temp: 50÷250°C, avec 1 grille cm.53x32,5 GN1/1 - Porte vitrée (il faut pas de induction) • **ES MUEBLE CON HORNO ELÉCTRICO MULTIFUNCIONAL CM. 64X37X35H, TEMP: 50÷250 °C, CON 1 PARILLA CM.53X32,5 GN1/1 - PUERTA VIDRIO (NO INDUCCIÓN)**  
**cm. 100x 57,5x 57h**



⚡ 3,05 kW **3.259,00**  
230V~ 59 / 0,53  
50/60 Hz

**MFM-610EM** BASE CON Forno elettrico multifunzione cm. 64x37x35h, temp: 50÷250°C, con 1 griglia cm.53x32,5 GN1/1 - Porta cieca inox (non sovrapporre elementi ad induzione)  
**EN** Stand with Multifunction electric oven cm. 64x37x35h, temp: 50÷250°C, with 1 grid cm.53x32,5 GN1/1 - Stainless steel door (no induction top) • **DE** unterbau mit Multifunktions-Elektroofen cm. 64x37x35h, temp: 50÷250°C, mit 1 Rost cm.53x32,5 GN1/1 - Edelstahltür (nicht Induktions) • **FR** placard avec Four électrique à fonctions multiples cm. 64x37x35h, temp: 50÷250°C, avec 1 grille cm.53x32,5 GN1/1 - Porte acier inoxydable (il faut pas de induction) • **ES MUEBLE CON HORNO ELÉCTRICO MULTIFUNCIONAL CM. 64X37X35H, TEMP: 50÷250 °C, CON 1 PARILLA CM.53X32,5 GN1/1 - PUERTA CIEGA INOX (NO INDUCCIÓN)**  
**cm. 100x 57,5x 57h**



⚡ 3,05 kW **3.259,00**  
230V~ 59 / 0,53  
50/60 Hz

**CMF-68** COPERCHIO per MFM-68E  
**EN** Lid for MFM-68E • **DE** Berichterstattung für MFM-68E • **FR** Couvercle pour MFM-68E • **ES CUBERTURA PARA MFM-68E**  
**cm. 80x 54x 2,8h**

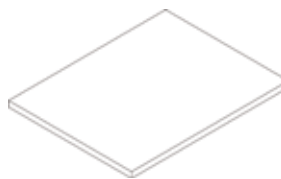

**224,00**  
4 / 0,02

**CMF-610** COPERCHIO per MFM-610E  
**EN** Lid for MFM-610E • **DE** Berichterstattung für MFM-610E • **FR** Couvercle pour MFM-610E • **ES CUBERTURA PARA MFM-610E**  
**cm. 100x 54x 2,8h**

**287,00**  
5 / 0,03

**MPI-64** BASE CON PORTA PER INDUZIONE  
**EN** Stand with door for induction top • **DE** Unterbau für Induktions mit Tür • **FR** Placard pour induction avec porte • **ES MUEBLE BASE PARA INDUCCIÓN CON PUERTA**  
**cm. 40x 51x 57h**



**678,00**  
18,5 / 0,19

# MOBILI BASE

MOD. \_\_\_\_\_  
COD. \_\_\_\_\_

DESCRIZIONE/DESCRIPTION/BEZEICHNUNG/DESCRIPTION/DESCRIPCIÓN  
DIMENSIONI/DIMENSIONS/ABMESSUNGEN/DIMENSIONS/DIMENSIONES

POTENZA/POWER/LEISTUNG/PUISSANCE/POTENCIA  
VOLTAGGIO/VOLTAGE/SPANNUNG/VOLTAGE/VOLTAJE

↓ kW kcal/h  
↑ kW V~ Hz

PREZZO/PRICE €  
PREIS/PRIX/PRECIO €  
KG / M<sup>3</sup>

**M-62** BASE NEUTRA  
06410200 **EN** Stand • **DE** Unterbau • **FR** Placard • **ES** MUEBLE BASE  
cm. **20x 48,5x 57h**



**389,00**  
11 / 0,15

**M-63** BASE NEUTRA a giorno  
06410300 **EN** Open Stand • **DE** Offener Unterbau • **FR** Placard ouvert • **ES**  
**MUEBLE BASE ABIERTO**  
cm. **30x 48,5x 57h**



**378,00**  
13 / 0,15

**M-64** cm. **40x 48,5x 57h**  
06410400



**423,00**  
15 / 0,19

**M-66** cm. **60x 48,5x 57h**  
06410600



**469,00**  
19 / 0,28

**M-67** cm. **70x 48,5x 57h**  
06410700



**514,00**  
20 / 0,37

**M-68** cm. **80x 48,5x 57h**  
06410800



**549,00**  
22 / 0,37

**M-69** cm. **90x 48,5x 57h**  
06410900



**685,00**  
25 / 0,53

**M-610** cm. **100x 48,5x 57h**  
06411000



**716,00**  
27 / 0,53

**M-612** cm. **120x 48,5x 57h**  
06411200



**765,00**  
32 / 0,55

**S-63** CAVALLETTO BASE  
06400300 **EN** Stand • **DE** Untergestell • **FR** Piedement simple • **ES** SOPORTE  
**BASE**  
cm. **30x 48,5x 57h**



**440,00**  
18 / 0,15

**S-64** cm. **40x 48,5x 57h**  
06400400



**461,00**  
19 / 0,19

**S-66** cm. **60x 48,5x 57h**  
06400600



**476,00**  
23 / 0,28

**S-68** cm. **80x 48,5x 57h**  
06400800



**589,00**  
26 / 0,37

**S-610** cm. **100x 48,5x 57h**  
06401000



**642,00**  
29 / 0,46

03/23  
**50**

Le immagini presentate non sono vincolanti. La ditta si riserva di apportare modifiche senza preavviso. • The pictures are purely representative. The manufacturer reserves the right to modify the technical data and models without previous notice. • Les images présentées ne nous engagent pas. La Société se réserve le

**LOTUS**

droit d'apporter tout modification sans préavis. • Die dargestellten Abbildungen sind nicht verbindlich. Technische Änderungen vorbehalten. • Las imágenes presentadas no son vinculantes. El Fabricante se reserva el derecho de modificar sus productos sin previo aviso.

**afaq**  
ISO 9001  
Qualità  
SINCE CERTIFICATION





# ACCESSORI

MOD. \_\_\_\_\_  
COD. \_\_\_\_\_

DESCRIZIONE/DESCRIPTION/BEZEICHNUNG/DESCRIPTION/DESCRIPCIÓN  
DIMENSIONI/DIMENSIONS/ABMESSUNGEN/DIMENSIONS/DIMENSIONES

POTENZA/POWER/LEISTUNG/PUISSANCE/POTENCIA  
VOLTAGGIO/VOLTAGE/SPANNUNG/VOLTAGE/VOLTAJE

⚡ kW kcal/h  
⚡ kW V~ Hz

PREZZO/PRICE €  
PREIS/PRIX/PRECIO €  
KG / M<sup>3</sup>

**PM-63/73/93-DX** PORTA 300 DESTRA  
08430302 **EN** Right door 300 • **DE** Rechte tür 300 • **FR** Porte droite 300 • **ES**  
**PUERTA DERECHA 300**  
cm. 29,5x 2,5x 47,5h



**213,00**  
3 / 0,01

**PM-64/74/94-DX** PORTA 400 DESTRA  
08430402 **EN** Right door 400 • **DE** Rechte tür 400 • **FR** Porte droite 400 • **ES**  
**PUERTA DERECHA 400**  
cm. 39,5x 2,5x 47,5h



**220,00**  
3.5 / 0,02

**PM-63/73/93-SX** PORTA 300 SINISTRA  
08430303 **EN** Left door 300 • **DE** Linke tür 300 • **FR** Porte gauche 300 • **ES**  
**PUERTA IZQUIERDA 300**  
cm. 29,5x 2,5x 47,5h



**213,00**  
3 / 0,01

**PM-64/74/94-SX** PORTA 400 SINISTRA  
08430403 **EN** Left door 400 • **DE** Linke tür 400 • **FR** Porte gauche 400 • **ES**  
**PUERTA IZQUIERDA 400**  
cm. 39,5x 2,5x 47,5h

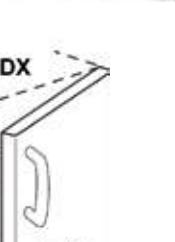

**220,00**  
3.5 / 0,02

M-610 = PM-64SX+PM-63SX+PM-63DX

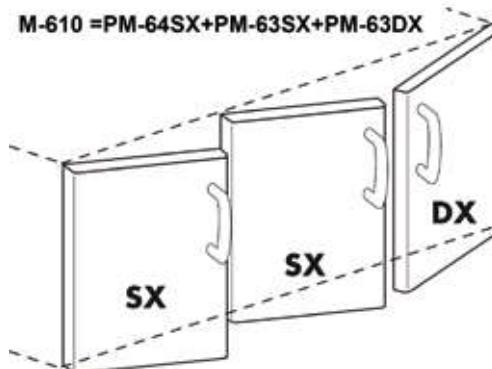

**C-63** CASSETTIERA 300/400/600 - N. 2 cassetti con vasca inox Guide  
06440320 telescopiche  
**EN** Drawer set 300/400/600 - N. 2 drawers with inox pans, telescopic  
guides • **DE** Schubladen 300/400/600 - N. 2 Schubladen mit  
chromnickelstahl Telescopeinführungen • **FR** Tiroirs pour meuble de  
300/400/600 - N. 2 tiroirs avec cuve inox, Guides télescopiques • **ES**  
**CAJONERA 300/400/600 - N. 2 CAJONES CON CUBA DE  
ACERO INOX, GUÍAS TELESCÓPICAS**  
cm. 29,5x 51x 47,5h



**742,00**  
8 / 0,15

**C-64** cm. 39,5x 51x 47,5h  
06440420

**766,00**  
9 / 0,19

# ACCESSORI

MOD. \_\_\_\_\_  
COD. \_\_\_\_\_

DESCRIZIONE/DESCRIPTION/BEZEICHNUNG/DESCRIPTION/DESCRIPCIÓN  
DIMENSIONI/DIMENSIONS/ABMESSUNGEN/DIMENSIONS/DIMENSIONES

POTENZA/POWER/LEISTUNG/PUISSANCE/POTENCIA  
VOLTAGGIO/VOLTAGE/SPANNUNG/VOLTAGE/VOLTAJE

⚡ kW kcal/h  
⚡ kw V~ Hz

PREZZO/PRICE €  
PREIS/PRIX/PRECIO €  
KG / M<sup>3</sup>

**C-66**  
06440620

cm. 59,5x 51x 47,5h



**895,00**  
14 / 0,28

**R-63**  
06450300

RIPIANO 300  
**EN** Shelf 300 • **DE** Zwischenboden 300 • **FR** Etagère 300 • **ES**  
**ESTANTE 300**  
cm. 25x 48x 2h

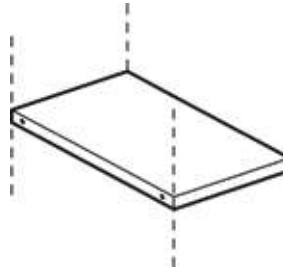

**90,00**  
1,5 / 0,01

**R-64**  
06450400

RIPIANO 400  
**EN** Shelf 400 • **DE** Abstellbrett 400 • **FR** Etagère 400 • **ES**  
**ESTANTE 400**  
cm. 35x 48x 2h

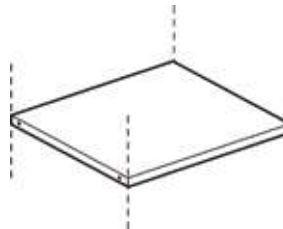

**100,00**  
2,5 / 0,01

**R-66**  
06450600

RIPIANO 600  
**EN** Shelf 600 • **DE** Abstellbrett 600 • **FR** Etagère 600 • **ES**  
**ESTANTE 600**  
cm. 55x 48x 2h

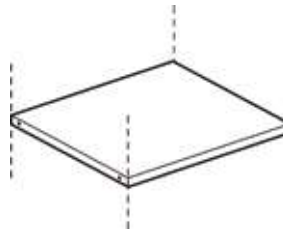

**113,00**  
3 / 0,01

**544023800** RASCHIETTO PER PIASTRA RIGATA  
**EN** Scraper for grooved plate • **DE** Schaber für gerillte Kochplatte  
• **FR** Racloir pour plaque nervurée • **ES RASQUETA PARA PLACA**  
**RANURADA**



**69,00**  
/ 1,00

**531040800** RASCHIETTO PER PIASTRA LISCIA AL CROMO LUCIDO  
**EN** Scraper for smooth POLISHED CHROME plate • **DE** Schaber für  
glatte POLIERTEM CHROM Platte • **FR** Racloir pour plaque lisse au  
CHROME POLI • **ES RASQUETA PARA PLACA LISA DE CROMO**  
**PULIDO**



**63,00**  
/ 1,00

**531040900** KIT 10 LAME PER RASCHIETTO cod.531040800  
**EN** 10 blades kit for scraper cod.531040800 • **DE** Kit 10 klingen  
für Schaber cod.531040800 • **FR** Kit de 10 lames pour racloir  
cod.531040800 • **ES KIT DE 10 CUCHILLAS PARA RASQUETA**  
**COD.531040800**

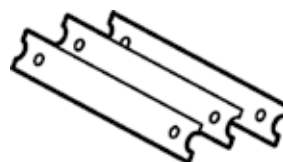

**45,00**  
/ 0,00

# ACCESSORI FRY-TOP





MOD. \_\_\_\_\_  
COD. \_\_\_\_\_

DESCRIZIONE/DESCRIPTION/BEZEICHNUNG/DESCRIPTION/DESCRIPCIÓN  
DIMENSIONI/DIMENSIONS/ABMESSUNGEN/DIMENSIONS/DIMENSIONES

POTENZA/POWER/LEISTUNG/PUISSANCE/POTENCIA  
VOLTAGGIO/VOLTAGE/SPANNUNG/VOLTAGE/VOLTAJE

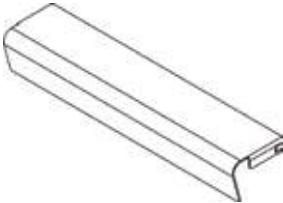
⚡ kW kcal/h  
⚡ kW V~ Hz

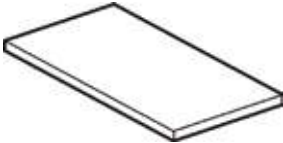
PREZZO/PRICE €  
PREIS/PRIX/PRECIO €  
KG / M<sup>3</sup>

<b>T-FT</b> 09580060	TAPPO PER FRY-TOP <b>EN</b> stopper for Fry-top • <b>DE</b> Stopfen griddleplatte • <b>FR</b> bouchon pour Plaque • <b>ES TAPÓN FRY-TOP</b> <b>cm. 10x 2x 5h</b>		<b>268,00</b> / 0,00
<b>PFT-64</b> 06620400	KIT PROTEZIONE FRONTALE PIANO FRY-TOP <b>EN</b> KIT front protection plan fry-top • <b>DE</b> Schutz-kit vorne Plan griddleplatte • <b>FR</b> KIT protection avant plan plaque • <b>ES KIT DE PROTECCIÓN FRONTAL PLAN DE FRY-TOP</b> <b>cm. 38x 8x 6h</b>		<b>137,00</b> / 0,00
<b>PFT-66</b> 06620600	<b>cm. 58x 8x 6h</b>		<b>186,00</b> / 0,01
<b>PFT-68</b> 06620800	<b>cm. 78x 8x 6h</b>		<b>233,00</b> / 0,01
<b>PFT-610</b> 06621000	<b>cm. 98x 8x 6h</b>		<b>265,00</b> / 0,01
<b>CG-60</b> 06560000	COPRIGIUNTO <b>EN</b> Joint cover • <b>DE</b> Klemmsteg • <b>FR</b> Couvre-joint • <b>ES CUBRE JUNTA</b> <b>cm. 0,7x 52x 1,2h</b>		<b>38,00</b> 0.12 / 1,00
<b>06550400</b>	COPERCHIO BR-64 <b>EN</b> Lid BR-64 • <b>DE</b> Deckel BR-64 • <b>FR</b> Couvercle BR-64 • <b>ES TAPA BR-64</b> <b>cm. 33x 45x 5h</b>		<b>150,00</b> / 0,02
<b>06550600</b>	COPERCHIO BR-66 <b>EN</b> Lid BR-66 • <b>DE</b> Deckel BR-66 • <b>FR</b> Couvercle BR-66 • <b>ES TAPA BR-66</b> <b>cm. 51x 42x 3h</b>		<b>151,00</b> / 0,02
<b>TG-63</b> 06580300	TAGLIERE PLASTICA <b>EN</b> Plastic chopping-board • <b>DE</b> Schneidebrett • <b>FR</b> Plan de decoupe • <b>ES PICADOR DE PLÁSTICO</b> <b>cm. 29x 52,5x 2,5h</b>		<b>138,00</b> 4 / 0,01
<b>TG-64</b> 06580400	<b>cm. 39x 52,5x 2,5h</b>		<b>151,00</b> 6 / 0,01
<b>TG-66</b> 06580600	<b>cm. 59x 52,5x 2,5h</b>		<b>253,00</b> 9 / 0,01
<b>TG-68</b> 06580800	<b>cm. 79x 52,5x 2,5h</b>		<b>297,00</b> 11 / 0,02
<b>PLF/62</b> 06590421	PIASTRA LISCIA 2 FUOCHI <b>EN</b> Smooth griddle plate 2 burners • <b>DE</b> Fortkochplatte glatt 2 Kochstellen • <b>FR</b> Plaque lisse 2 feux • <b>ES PLANCHA LISA 2 QUEMADORES</b> <b>cm. 29x 50</b>		<b>246,00</b> 15 / 0,01

60

# ACCESSORI

MOD. \_\_\_\_\_  
COD. \_\_\_\_\_

DESCRIZIONE/DESCRIPTION/BEZEICHNUNG/DESCRIPTION/DESCRIPCIÓN  
DIMENSIONI/DIMENSIONS/ABMESSUNGEN/DIMENSIONS/DIMENSIONES

POTENZA/POWER/LEISTUNG/PUISSANCE/POTENCIA  
VOLTAGGIO/VOLTAGE/SPANNUNG/VOLTAGE/VOLTAJE

⚡ kW kcal/h  
⚡ kw V~ Hz

PREZZO/PRICE €  
PREIS/PRIX/PRECIO €  
KG / M<sup>3</sup>

**PRF/62**  
06590423  
PIASTRA RIGATA 2 FUOCHI  
**EN** Grooved griddle plate 2 burners • **DE** Fortkochplatte gerillt 2 Kochstellen • **FR** Plaque nervurée 2 feux • **ES** PLANCHA ESTRIADA 2 QUEMADORES  
cm. 29x 50



**361,00**  
15 / 0,01

**533009100** GRIGLIA DI RIDUZIONE  
**EN** Reduction • **DE** Reduzierstern • **FR** Grille de réduction • **ES** REJILLA DE REDUCCIÓN  
cm. 15x 15



**24,00**  
0,2 / 0,00

**533009200** GRIGLIA DI RIDUZIONE PER PC1/2/3T E CF2/3  
**EN** Reduction PC1/2/3T & CF2/3 • **DE** Reduzierstern PC1/2/3T & CF2/3 • **FR** Grille de réduction PC1/2/3T & CF2/3 • **ES** REJILLA DE REDUCCIÓN PC1/2/3T & CF2/3  
cm. 25x 25

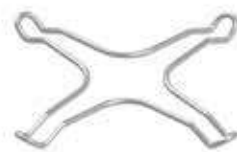

**43,00**  
0.2 / 0,00

**RV**  
08660410  
RISCALDANTE VANO  
**EN** Heater for cabinet • **DE** Heizer für Schrankelement • **FR** Réchauffeur pour armoire • **ES** ELEMENTO DE CALEFACCIÓN PARA ARMARIO NEUTRO  
cm. 32x 48,5x 8h

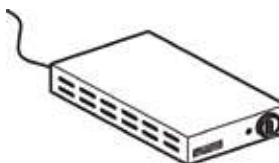

⚡ 0,75 kW  
230V~  
50/60 Hz  
**975,00**  
8 / 0,08

**RRV-64**  
06450401  
RIPIANO FORATO IN APPOGGIO PER RISCALDANTE (NO CF)  
**EN** Perforated shelf for heater element mod.RV (NO CF) • **DE** regale Gelocht für Heizer mod.RV (NO CF) • **FR** Étagère perforées pour réchauffeur mod.RV (NO CF) • **ES** ESTANTE PERFORADO PARA ELEMENTO DE CALEFACCIÓN MOD.RV (NO CF)  
cm. 34x 46x 10h



**337,00**  
4 / 0,02

**RRV-66**  
06450601  
cm. 54x 46x 10h

**507,00**  
5 / 0,04

**RRV-67**  
06450701  
cm. 64x 46x 10h

**637,00**  
6 / 0,04

**RRV-68**  
06450801  
cm. 74x 46x 10h

**649,00**  
7 / 0,05

**RRV-69**  
06450901  
cm. 84x 46x 10h

**816,00**  
8 / 0,06

**RRV-610**  
06451001  
cm. 94x 46x 10h

**918,00**  
10 / 0,06

**RRV-612**  
06451201  
cm. 114x 46x 10h

**1.093,00**  
12 / 0,08

# ACCESSORI

MOD. \_\_\_\_\_  
COD. \_\_\_\_\_

DESCRIZIONE/DESCRIPTION/BEZEICHNUNG/DESCRIPTION/DESCRIPCIÓN  
DIMENSIONI/DIMENSIONS/ABMESSUNGEN/DIMENSIONS/DIMENSIONES

POTENZA/POWER/LEISTUNG/PUISSANCE/POTENCIA  
VOLTAGGIO/VOLTAGE/SPANNUNG/VOLTAGE/VOLTAJE

$\frac{kW}{kcal/h}$   $\frac{kw}{V\sim}$   
Hz

PREZZO/PRICE €  
PREIS/PRIX/PRECIO €  
KG / M<sup>3</sup>

**KIT-WOK**  
09580040

KIT WOK - fiamma verticale - solo su bruciatore da 10 kW e griglie in ghisa  
**EN** KIT WOK - vertical flame - only for 10 kW burner and cast iron grills  
• **DE** KIT WOK - vertikaler Flamme - nur 10 kW-Brenner und Roste aus Gusseisen • **FR** KIT WOK - verticale de la flamme - seulement 10 kW brûleur et grilles en fonte • **ES KIT WOK - LLAMA VERTICAL - SÓLO 10 KW QUEMADOR Y PARRILAS DE HIERRO COLADO**  
cm. Ø 26x 16h



**456,00**  
5 / 0,02

**544439900**

ANELLO PER WOK - solo per griglie in ghisa  
**EN** Wok ring - only for cast iron grills • **DE** Wok Aufsatzring - nur für Roste aus Gusseisen • **FR** Anneau Wok - seulement pour grilles en fonte • **ES ANILLO WOK - SOLO PARA PARRILAS DE HIERRO COLADO**  
cm.Ø22,5x 3,5h



**170,00**  
2 / 0,00

**SIA-7/9**  
08480000

STAFFA INFERIORE UNIONE APPARECCHI  
**EN** Lower bracket to join two items

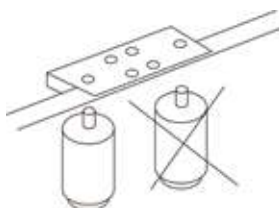

**64,00**  
2 / 0,00

**SR-100**  
50900001

SET 4 RUOTE Ø 100x30, 2 con freno  
**EN** Set of 4 wheels Ø 100x30, 2 with brake • **DE** 4 Rollen Satz Ø 100x30, 2 davon mit Feststellbremse • **FR** Kit 4 roues Ø 100x30, 2 avec frein • **ES EQUIPO 4 RUEDAS Ø 100X30, 2 CON FRENOS**  
cm. 12,7h

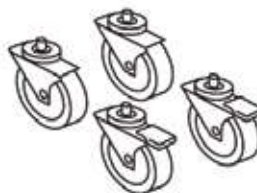

**383,00**  
1 / 0,01

**ZB**  
01410000

ZOCOLATURA BASE  
**EN** FRONT PLINTH • **DE** GRUNDSOCKEL • **FR** PLINTHE FRONTAL  
• **ES** ZOCOLOS BASE  
€/m x cm. 15h

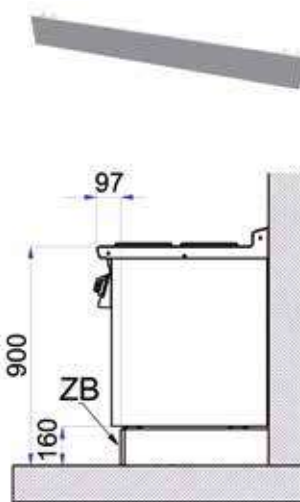

**154,00**  
/

**ZA**  
01410002

ZOCOLATURA ANGOLO  
**EN** CORNER PLINTH • **DE** EKE-SOCKEL • **FR** PLINTHE ANGLE • **ES** ZOCOLOS ANGULAR  
cm. 15h

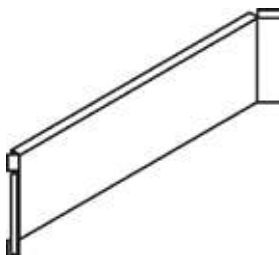

**93,00**  
0.3 / 0,01

MOD. \_\_\_\_\_  
COD. \_\_\_\_\_

DESCRIZIONE/DESCRIPTION/BEZEICHNUNG/DESCRIPTION/DESCRIPCIÓN  
DIMENSIONI/DIMENSIONS/ABMESSUNGEN/DIMENSIONS/DIMENSIONES

POTENZA/POWER/LEISTUNG/PUISSANCE/POTENCIA  
VOLTAGGIO/VOLTAGE/SPANNUNG/VOLTAGE/VOLTAJE

⚡ kW kcal/h  
⚡ kW V~ Hz

PREZZO/PRICE €  
PREIS/PRIX/PRECIO €  
KG / M<sup>3</sup>

**D-60**  
06470000

DIVISORIO - Necessario per applicare cassettera C-64 su mobile 70/80  
**EN** Spacer - For installation of a C-64 on a stand 70/80 • **DE**  
Trennwand - Um ein C-64 an einem Unterschrank 70/80 einzubauen  
• **FR** Separation - Pour l'installation de C-64 sur placard 70/80 • **ES**  
**DIVISORIO - NECESARIO PARA APLICAR CAJONERAS C-64**  
**EN MUEBLE 70/80**  
cm. **5x 48x 38h**

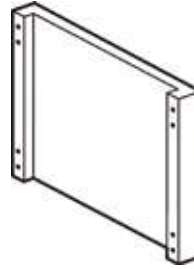

**164,00**  
2 / 0,02

**PT-64**  
06460002

PORTATEGLIE VANO - 400 (GN2/3) - VANO 600 (GN1/1)  
**EN** Frame for oven plates. 400 GN 2/3 - 600 GN 1/1 • **DE**  
Auflangeschienen für Backbleche. 400 GN 2/3 - 600 GN 1/1 • **FR** Kit  
porte-plaques. 400 GN 2/3 - 600 GN 1/1 • **ES** **PORTACAZUELAS.**  
**400 GN 2/3 - 600 GN 1/1**  
cm. **2x 47x 30h**

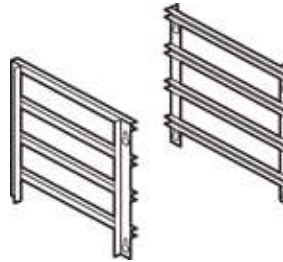

**347,00**  
2.5 / 0,01

**06570401**

GRIGLIA TONDINO per CW64 (SERIE 60)  
**EN** Grid for CW-64 (60 line) • **DE** Gitter für CW-64 (60. Serie) • **FR**  
Grille ronde pour CW-64 (serie 60) • **ES** **REJILLA PARA CW-64**  
**(SERIE 60)**  
cm. **38x 42**



**410,00**  
9 / 0,02  
18,28  
Ø 6

**06570601**

GRIGLIA TONDINO per CW66 (SERIE 60)  
**EN** Grid for CW-66 (60 line) • **DE** Gitter für CW-66 (60. Serie) • **FR**  
Grille ronde pour CW-66 (serie 60) • **ES** **REJILLA PARA CW-66**  
**(SERIE 60)**  
cm. **58x 42**



**584,00**  
9 / 0,03  
18,28  
Ø 6

**06570402**

GRIGLIA TEGOLO V per CW-64 (SERIE 60)  
**EN** V TRAY for CW-64 ( 60 LINE) • **DE** V ROSTE FÜR CW-64 (60  
LINIE) • **FR** V GRILLE POUR CW-64 ( LIGNE 60) • **ES** **V REJILLA**  
**PARA CW-64 (SERIE 60)**  
cm. **36x 43**



**280,00**  
9 / 0,02  
5  
23,5

**06570602**

GRIGLIA TEGOLO V per CW-66 (SERIE 60)  
**EN** V TRAY for CW-66 ( 60 LINE) • **DE** V ROSTE FÜR CW-66 (60  
LINIE) • **FR** V GRILLE POUR CW-66 ( LIGNE 60) • **ES** **V REJILLA**  
**PARA CW-66 (SERIE 60)**  
cm. **56x 43**



**404,00**  
9 / 0,03  
5  
23,5

# ACCESSORI CUOCIPASTA

MOD. \_\_\_\_\_  
COD. \_\_\_\_\_

DESCRIZIONE/DESCRIPTION/BEZEICHNUNG/DESCRIPTION/DESCRIPCIÓN  
DIMENSIONI/DIMENSIONS/ABMESSUNGEN/DIMENSIONS/DIMENSIONES

POTENZA/POWER/LEISTUNG/PUISSANCE/POTENCIA  
VOLTAGGIO/VOLTAGE/SPANNUNG/VOLTAGE/VOLTAJE

⚡ kW kcal/h  
⚡ kW V~ Hz

PREZZO/PRICE €  
PREIS/PRIX/PRECIO €  
KG / M<sup>3</sup>

**531017900** CESTO 1/3 PER CP-66  
**EN** Basket 1/3 for CP-66 • **DE** Korb 1/3 für CP-66 • **FR** Panier 1/3 pour CP-66 • **ES CESTA 1/3 PARA CP-66**  
**cm. 16x 29x 20h**

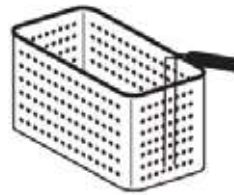

..179..

**145,00**  
1,5 / 0,05

**531064300** CESTO 1/4 PER CP-66  
**EN** Basket 1/4 for CP-66 • **DE** Korb 1/4 für CP-66 • **FR** Panier 1/4 pour CP-66 • **ES CESTA 1/4 PARA CP-66**  
**cm. 11,5x 29x 20h**

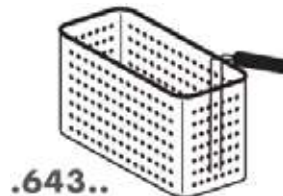

..643..

**130,00**  
1,2 / 0,04

**531053900** CESTO 1/1 PER CP-66  
**EN** Basket 1/1 for CP-66 • **DE** Korb 1/1 für CP-66 • **FR** Panier 1/1 pour CP-66 • **ES CESTA 1/1 PARA CP-66**  
**cm. 49x 29x 20h**

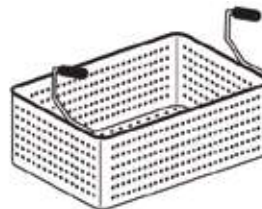

..539..

**198,00**  
3,5 / 0,08

**531018800** CESTO 1/2 PER CPT-64 - 1/3 PER CPT-66  
**EN** Basket 1/2 for CPT-64 - 1/3 for CPT-66 • **DE** Korb 1/2 für CPT-64 - 1/3 für CPT-66 • **FR** Panier 1/2 pour CPT-64 - 1/3 pour CPT-66 • **ES CESTA 1/2 PARA CPT-64 - 1/3 PARA CPT-66**  
**cm. 14,5x 29x 15h**

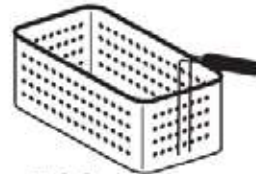

..188..

**138,00**  
1,3 / 0,04

**531053800** CESTO 1/4 PER CPT-66  
**EN** Basket 1/4 for CPT-66 • **DE** Korb 1/4 für CPT-66 • **FR** Panier 1/4 pour CPT-66 • **ES CESTA 1/4 PARA CPT-66**  
**cm. 11,5x 29x 15h**

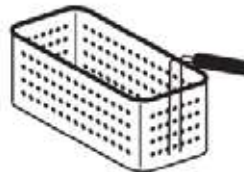

..538..

**132,00**  
1,2 / 0,04

**531040000** CESTO 1/1 PER CPT-66  
**EN** Basket 1/1 for CPT-66 • **DE** Korb 1/1 für CPT-66 • **FR** Panier 1/1 pour CPT-66 • **ES CESTA 1/1 PARA CPT-66**  
**cm. 49x 29x 15h**



..400..

**238,00**  
3,5 / 0,07

**531048900** CESTO 1/6 PER CPT-64  
**EN** Basket 1/6 for CPT-64 • **DE** Korb 1/6 für CPT-64 • **FR** Panier 1/6 pour CPT-64 • **ES CESTA 1/6 PARA CPT-64**  
**cm. 14x 10x 15h**



**86,00**  
1 / 0,01

# ACCESSORI CUOCIPASTA

MOD. \_\_\_\_\_  
COD. \_\_\_\_\_

DESCRIZIONE/DESCRIPTION/BEZEICHNUNG/DESCRIPTION/DESCRIPCIÓN  
DIMENSIONI/DIMENSIONS/ABMESSUNGEN/DIMENSIONS/DIMENSIONES

POTENZA/POWER/LEISTUNG/PUISSANCE/POTENCIA  
VOLTAGGIO/VOLTAGE/SPANNUNG/VOLTAGE/VOLTAJE

↓ kW kcal/h  
↑ kW V~ Hz

PREZZO/PRICE €  
PREIS/PRIX/PRECIO €  
KG / M<sup>3</sup>

**531053700** CESTO 1/4 PER CPT-64  
**EN** Basket 1/4 for CPT-64 • **DE** Korb 1/4 für CPT-64 • **FR** Panier 1/4 pour CPT-64 • **ES CESTA 1/4 PARA CPT-64**  
**cm. 14x 16x 15h**



..537..

**93,00**  
1 / 0,02

**531053500** CESTO 1/1 PER CPT-64  
**EN** Basket 1/1 for CPT-64 • **DE** Korb 1/1 für CPT-64 • **FR** Panier 1/1 pour CPT-64 • **ES CESTA 1/1 PARA CPT-64**  
**cm. 29x 29x 15h**

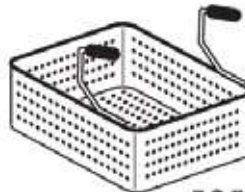

..535..

**171,00**  
1,5 / 0,05

**531071300** CESTO CON GANCIO 1/2 PER CPT-64 - 1/3 PER CPT-66  
**EN** Basket with hook 1/2 for CPT-64 - 1/3 for CPT-66 • **DE** Korb mit Haken 1/2 für CPT-64 - 1/3 für CPT-66 • **FR** Panier avec crochet 1/2 pour CPT-64 - 1/3 pour CPT-66 • **ES CESTA CON GANCHO 1/2 PARA CPT-64 - 1/3 PARA CPT-66**  
**cm. 13,5x 25,5x 15h**



**137,00**  
1,3 / 0,04

**531071400** CESTO CON GANCIO 1/4 PER CPT-66  
**EN** Basket with hook 1/4 for CPT-66 • **DE** Korb mit Haken 1/4 für CPT-66 • **FR** Panier avec crochet 1/4 pour CPT-66 • **ES CESTA CON GANCHO 1/4 PARA CPT-66**  
**cm. 11x 25,5x 15h**

**130,00**  
1,2 / 0,03

**531071200** CESTO CON GANCIO 1/3 PER CP-66  
**EN** Basket with hook 1/3 for CP-66 • **DE** Korb mit Haken 1/3 für CP-66 • **FR** Panier avec crochet 1/3 pour CP-66 • **ES CESTA CON GANCHO 1/3 PARA CP-66**  
**cm. 15x 26x 20h**

**158,00**  
1,5 / 0,05

**531018700** CESTO CON GANCIO 1/4 PER CP-66  
**EN** Basket with hook 1/4 for CP-66 • **DE** Korb mit Haken 1/4 für CP-66 • **FR** Panier avec crochet 1/4 pour CP-66 • **ES CESTA CON GANCHO 1/4 PARA CP-66**  
**cm. 11x 26x 20h**

**131,00**  
1,2 / 0,04

**531069400** GRIGLIA SUPPORTO CESTI CON GANCIO PER CP-66  
**EN** support for baskets with hook for CP-66 • **DE** Unterstützung für Körbe mit Haken für CP-66 • **FR** soutien pour les paniers avec crochet pour CP-66 • **ES SOPORTE PARA CESTAS CON GANCHO PARA CP-66**  
**cm. 50x 29x 41h**



**195,00**  
4 / 0,09

**531071800** GRIGLIA SUPPORTO CESTI CON GANCIO PER CPT-64  
**EN** support for baskets with hook for CPT-64 • **DE** Unterstützung für Körbe mit Haken für CPT-64 • **FR** soutien pour les paniers avec crochet pour CPT-64 • **ES SOPORTE PARA CESTAS CON GANCHO PARA CPT-64**  
**cm. 30x 33x 25h**



**138,00**  
3 / 0,04



# ACCESSORI CUOCIPASTA

MOD. \_\_\_\_\_  
COD. \_\_\_\_\_

DESCRIZIONE/DESCRIPTION/BEZEICHNUNG/DESCRIPTION/DESCRIPCIÓN  
DIMENSIONI/DIMENSIONS/ABMESSUNGEN/DIMENSIONS/DIMENSIONES

POTENZA/POWER/LEISTUNG/PUISSANCE/POTENCIA  
VOLTAGGIO/VOLTAGE/SPANNUNG/VOLTAGE/VOLTAJE

↓ kW kcal/h  
↑ kW V~ Hz

PREZZO/PRICE €  
PREIS/PRIX/PRECIO €  
KG / M<sup>3</sup>

**531071900** GRIGLIA SUPPORTO CESTI CON GANCIO PER CPT-66  
**EN** support for baskets with hook for CPT-66 • **DE** Unterstützung für Körbe mit Haken für CPT-66 • **FR** soutien pour les paniers avec crochet pour CPT-66 • **ES SOPORTE PARA CESTAS CON GANCHO PARA CPT-66**  
cm. 50x 30x 25h



**179,00**  
3,5 / 0,06

**531013200** CESTO 1/2 PER F13-64E / F10T-63E  
**EN** Basket 1/2 for F13-64E / F10T-63E • **DE** Korb 1/2 für F13-64E / F10T-63E • **FR** Panier 1/2 pour F13-64E / F10T-63E • **ES CESTA 1/2 PARA F13-64E / F10T-63E**  
cm. 10x 30x 12h



**63,00**  
0.7 / 0,03

**531053300** CESTO 1/2 PER F13-64G  
**EN** Basket 1/2 for F13-64G • **DE** Korb 1/2 für F13-64G • **FR** Panier 1/2 pour F13-64G • **ES CESTA 1/2 PARA F13-64G**  
cm. 15x 27x 12h

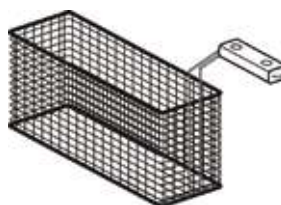

**85,00**  
0.7 / 0,04

**SA-62** SCHIENA POSTERIORE A VISTA PER APPARECCHI  
06600200 **EN** Back cover • **DE** Rückenwand • **FR** Dos de finition • **ES PANEL POSTERIOR**  
cm. 20x 1,5x 81h



**112,00**  
2 / 0,01

**SA-63** cm. 30x 1,5x 81h  
06600300

**SA-64** cm. 40x 1,5x 81h  
06600400

**SA-66** cm. 60x 1,5x 81h  
06600600

**SA-68** cm. 80x 1,5x 81h  
06600800

**SA-610** cm. 100x 1,5x 81h  
06601000

**SA-612** cm. 120x 1,5x 81h  
06601200

**SA-63FG** SCHIENA POSTERIORE A VISTA PER FRIGGITRICI GAS  
06600301 **EN** Back cover for Gas Fryer • **DE** Rückenwand für Gas-Friteuse • **FR** Dos de finition pour Friteuse a gaz • **ES PANEL POSTERIOR PARA FREIDORAS A GAS**  
cm. 30x 1,5x 90h

**135,00**  
3 / 0,01

**SA-66FG** cm. 60x 1,5x 90h  
06600601

**226,00**  
4 / 0,02

# ACCESSORI

MOD. \_\_\_\_\_  
COD. \_\_\_\_\_

DESCRIZIONE/DESCRIPTION/BEZEICHNUNG/DESCRIPTION/DESCRIPCIÓN  
DIMENSIONI/DIMENSIONS/ABMESSUNGEN/DIMENSIONS/DIMENSIONES

POTENZA/POWER/LEISTUNG/PUISSANCE/POTENCIA  
VOLTAGGIO/VOLTAGE/SPANNUNG/VOLTAGE/VOLTAJE

⚡ kW kcal/h  
⚡ kW V~ Hz

PREZZO/PRICE €  
PREIS/PRIX/PRECIO €  
KG / M<sup>3</sup>

**KIT-TOPM-SA** KIT TAMPONAMENTI LATERALI per schiena posteriore montata su apparecchi TOP e mobili "M..."  
08600001 **EN** Side KIT for back cover mounted on the TOP machine and Stand "M..." • **DE** Seitliches KIT für Rückenwand montiert auf der TOP-Maschine und Unterbau "M..." • **FR** KIT latéral pour Dos de finition monté sur la machine TOP et Placard "M..." • **ES KIT LATERAL PARA PANEL POSTERIORE MONTADO EN LA MÁQUINA TOP Y MUEBLE BASE "M..."**

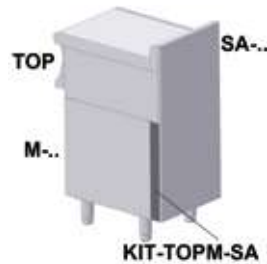

**99,00**  
1 / 0,01

**TMA-6SX** TESTATA 1 LATO SERIE 60 SINISTRA  
06540601 **EN** Head 1 side S60 left • **DE** Abschluss element 1 seite S60 links • **FR** Element de jonction 1 coté S60 gauche • **ES EMBELLECEDOR 1 LADO S60 IZQUIERDA**  
**cm. 0,2x 60**



**267,00**  
7 / 0,02

**TMA-6DX** TESTATA 1 LATO SERIE 60 DESTRA  
06540600 **EN** Head 1 side S60 right • **DE** Abschluss element 1 seite S60 recht • **FR** Element de jonction 1 coté S60 droit • **ES EMBELLECEDOR 1 LADO S60 DERECHA**  
**cm. 0,2x 60**



**267,00**  
7 / 0,02

**TMA-66** TESTATA 2 LATI SERIE 60  
06546600 **EN** Head 2 sides S60 • **DE** Abschluss element seiten S60 • **FR** Element de jonction 2 cotés S60 • **ES EMBELLECEDOR 2 LADOS S60**  
**cm. 0,2x 120**



**534,00**  
14 / 0,04

**TMA-67SX** TESTATA 2 LATI SERIE 60/70 SINISTRA  
06546701 **EN** Head 2 sides S60/70 left • **DE** Abschluss element seiten S60/70 links • **FR** Element de jonction 2 cotés S60/70 gauche • **ES EMBELLECEDOR 2 LADOS S60/70 IZQUIERDA**  
**cm. 0,2x 130,5**



**545,00**  
15 / 0,04

**TMA-67DX** TESTATA 2 LATI SERIE 60/70 DESTRA  
06546700 **EN** Head 2 sides S60/70 right • **DE** Abschluss element seiten S60/70 recht • **FR** Element de jonction 2 cotés S60/70 droit • **ES EMBELLECEDOR 2 LADOS S60/70 DERECHA**  
**cm. 0,2x 130,5**



**545,00**  
15 / 0,04

03/23  
**60**

Le immagini presentate non sono vincolanti. La ditta si riserva di apportare modifiche senza preavviso. • The pictures are purely representative. The manufacturer reserves the right to modify the technical data and models without previous notice. • Les images présentées ne nous engagent pas. La Société se réserve le

**LOTUS**

droit d'apporter tout modification sans préavis. • Die dargestellten Abbildungen sind nicht verbindlich. Technische Änderungen vorbehalten. • Las imágenes presentadas no son vinculantes. El Fabricante se reserva el derecho de modifi car sus productos sin previo aviso.

**afaq**  
ISO 9001  
Qualità  
ENAC CERTIFICATION



# ACCESSORI

MOD. \_\_\_\_\_  
COD. \_\_\_\_\_

DESCRIZIONE/DESCRIPTION/BEZEICHNUNG/DESCRIPTION/DESCRIPCIÓN  
DIMENSIONI/DIMENSIONS/ABMESSUNGEN/DIMENSIONS/DIMENSIONES

POTENZA/POWER/LEISTUNG/PUISSANCE/POTENCIA  
VOLTAGGIO/VOLTAGE/SPANNUNG/VOLTAGE/VOLTAJE

⚡ kW kcal/h  
⚡ kW V~ Hz

PREZZO/PRICE €  
PREIS/PRIX/PRECIO €  
KG / M<sup>3</sup>

**TMA-69SX**  
06546901

TESTATA 2 LATI SERIE 60/90 SINISTRA  
**EN** Head 2 sides S60/90 left • **DE** Abschluss element seiten S60/90 links • **FR** Element de jonction 2 cotés S60/90 gauche • **ES** **EMBELLECEDOR 2 LADOS S60/90 IZQUIERDA**  
cm. 0,2x 150



**575,00**  
16 / 0,04

**TMA-69DX**  
06546900

TESTATA 2 LATI SERIE 60/90 DESTRA  
**EN** Head 2 sides S60/90 right • **DE** Abschluss element seiten S60/90 recht • **FR** Element de jonction 2 cotés S60/90 droit • **ES** **EMBELLECEDOR 2 LADOS S60/90 DERECHA**  
cm. 0,2x 150



**575,00**  
16 / 0,04

**BCC**  
16000000

BLOCCO COTTURA CARRELLATO Composto da: BRS-161, F10T-63ET, PLT-64, TG-64, FTLRT-66ET, PLT-63, HP-4, TS-6  
**EN** Cooking unit on trolley - Made of: BRS-161, F10T-63ET, PLT-64, TG-64, FTLRT-66ET, PLT-63, HP-4, TS-6 • **DE** Kochvorrichtung mit Fahrbarem gestell Anbauteile: BRS-161, F10T-63ET, PLT-64, TG-64, FTLRT-66ET, PLT-63, HP-4, TS-6 • **FR** Bloc cuisson roulant - Elements de composition: BRS-161, F10T-63ET, PLT-64, TG-64, FTLRT-66ET, PLT63, HP-4, TS-6 • **ES** **BLOQUE COCCIÓN CON RUEDAS - COMPUESTO POR: BRS-161, F10T-63ET, PLT-64, TG-64, FTLRT-66ET, PLT-63, HP-4, TS-6**  
cm. 220x 65x 110h



⚡ 15,48 kW **17.235,00**  
400V~3N 260 / 2,29  
230V~3  
50 Hz

60